

2016

# Atypical cystic fibrosis: from the genetic causes to current and future treatments

---

<https://hdl.handle.net/2144/16830>

*Downloaded from DSpace Repository, DSpace Institution's institutional repository*

BOSTON UNIVERSITY  
SCHOOL OF MEDICINE

Thesis

**ATYPICAL CYSTIC FIBROSIS: FROM THE GENETIC CAUSES TO  
CURRENT AND FUTURE TREATMENTS**

by

**RYAN QUINN**

B.S., University of California, Santa Barbara, 2013

Submitted in partial fulfillment of the  
requirements for the degree of  
Master of Science

2016

© 2016 by  
RYAN QUINN  
All rights reserved

Approved by

First Reader

---

Matthew D. Layne, Ph.D  
Associate Professor of Biochemistry

Second Reader

---

Karen Symes, Ph.D  
Associate Professor of Biochemistry

## **ACKNOWLEDGMENTS**

I would like to sincerely thank my thesis readers: Dr. Matthew Layne (first reader) and Dr. Karen Symes (second reader). Dr. Layne not only served as the first reader of my thesis, but also served as my advisor throughout the MAMS program. Dr. Layne spent countless hours meeting with me and preparing me for medical school interviews – going far beyond the typical job description of a graduate student advisor, and mentor. I can't thank Dr. Layne enough for his continuous support throughout my time at Boston University.

Second, I would like to thank my parents for their support of my goal to pursue a career in medicine, and their unwavering confidence in me. This program represented a significant investment in my future, and I am grateful for their help.

Third, I would like to acknowledge my many dedicated peers that I met through the program. I enjoyed the collaboration and the journey together in pursuit of our shared dream to make a difference to others through medicine.

**ATYPICAL PRESENTATION OF CYSTIC FIBROSIS: FROM THE GENETIC  
CAUSES TO CURRENT AND FUTURE TREATMENTS**

**RYAN QUINN**

**ABSTRACT**

Cystic Fibrosis (CF) is a life threatening autosomal recessive disorder caused by a mutation in the Cystic Fibrosis Transmembrane Conductance Regulator (CFTR) gene, leading to irregular secretions and inflammation in tubular organs. Disease manifestations of CF are heterogeneous in severity and can be present in the sinopulmonary, hepatic, gastrointestinal, and genitourinary tract. Since the 1960's, physicians and scientists have described a less severe form of CF known as atypical CF, usually seen in adults. Patients with atypical CF tend to have one severe CF mutation on one chromosome, and one less common, mild CF mutation on their other chromosome; or have one severe mutation on one chromosome and an abnormal number of trinucleotide repeats in the CFTR gene on their other chromosome. Today, of the approximately 1000 patients diagnosed with CF per year in the United States, roughly 10% are diagnosed with the atypical presentation of the disease as adults. Patients suffering from atypical CF typically have only one organ system that is dysfunctional, and their clinical symptoms may be less severe than those of a classical case where there are two severe CF mutations. Common symptoms include idiopathic bronchiectasis, chronic sinusitis, congenital bilateral absence of the vas deferens (CBAVD), and idiopathic pancreatitis. Unlike patients suffering from the classical presentation of the disease, most are pancreatic sufficient – however the possibility of pancreatic insufficiency still exists. Patients with atypical CF represent a

diagnostic challenge for physicians due to the mild, slowly progressing array of clinical symptoms, the general lack of knowledge about atypical CF, and the general association of CF as a childhood disease. Increasing physician awareness of the adult population with CF is a paramount in improving the diagnosis, care and treatment of patients with atypical CF. Missed diagnoses can result in hospital admissions and morbidity that may have been avoidable. The goal of this thesis is to describe the causes of CF, the common symptoms seen in both CF and atypical CF, the proper diagnosis of atypical CF, and to identify the therapies, both current and in development, used to treat atypical CF.

## TABLE OF CONTENTS

|  |      |
|--|------|
| ACKNOWLEDGMENTS .....  | iv   |
| ABSTRACT .....   | v    |
| LIST OF TABLES .....   | viii |
| LIST OF FIGURES .....  | ix   |
| LIST OF ABBREVIATIONS.....   | x    |
| INTRODUCTION .....   | 1    |
| PART 1: THE CFTR TRANSPORTER.....  | 6    |
| A) CFTR Protein Structure:.....  | 6    |
| B) The Basic Problem – How Dysfunctional CFTR Causes Problems:.....        | 8    |
| 1) Mechanism of lung dysfunction due to defective CFTR:.....               | 8    |
| 2) Mechanism of Pancreatic Dysfunction Due to Defective CFTR:.....         | 11   |
| C) Mutations in the CFTR Gene: .....                                       | 13   |
| D) Genotype-Phenotype Correlation and Variation in Disease Severity: ..... | 18   |
| E) What are the Genetic Modifiers? .....                                   | 19   |
| PART 2: CF AND ATYPICAL CF SIGNS AND SYMPTOMS.....                         | 22   |
| Classical CF:.....   | 22   |
| Atypical CF: .....   | 23   |
| PART 3: DIAGNOSING ATYPICAL and CLASSICAL CYSTIC FIBROSIS .....            | 29   |
| A Case Study: Diagnosis of Atypical CF in a 55-year-old Female:.....       | 35   |
| PART 4: TREATMENT OF ATYPICAL CF .....                                     | 38   |
| 1) Traditional Therapies to Treat Pulmonary Atypical CF Symptoms: .....    | 39   |
| Antibiotics: .....   | 40   |
| Bronchodilators and Corticosteroids:.....                                  | 42   |
| Chest Physical Therapy:.....   | 43   |
| Hypertonic Saline:.....  | 43   |
| Mucolytic Agents: .....  | 44   |
| Orally administered NSAIDS: .....  | 45   |
| 2) Traditional Therapies to Treat GI Based Atypical CF Symptoms: .....     | 45   |
| 3) Current and Future Targeted Therapies: .....                            | 48   |
| PART 5: CONCLUSIONS .....  | 52   |
| REFERENCES .....   | 54   |
| CURRICULUM VITAE.....  | 62   |



## LIST OF TABLES

| Table | Title   | Page  |
|-------|---|-------|
| 1     | Summary of CFTR Mutation Classes  | 14    |
| 2     | Genotype Distribution in Patients with Early and Late Diagnosed Cystic Fibrosis | 17    |
| 3     | Summary of Symptoms Associated with Atypical Cystic Fibrosis                    | 28    |
| 4     | Clinical Presentations at the Time of Diagnosis.                                | 28    |
| 5     | Pulmonary Treatments from the Cystic Fibrosis Foundation (CFF)                  | 46-47 |

## LIST OF FIGURES

| Figure | Title   | Page |
|--------|---|------|
| 1      | CFTR Protein Structure  | 7    |
| 2      | Wild Type versus Cystic Fibrosis CFTR Ion Transport in the Respiratory Epithelium | 10   |
| 3      | Pancreatic Duct Cell and CFTR   | 12   |
| 4      | An Algorithm for Cystic Fibrosis Diagnosis  | 31   |
| 5      | Nasal Potential Difference Testing in Normal and Cystic Fibrosis Individuals      | 33   |

## LIST OF ABBREVIATIONS

|                    |  |
|--------------------|--|
| cAMP .....         | Cyclic adenosine monophosphate                       |
| CBAVD.....         | Congenital Bilateral Absence of the Vas Deferens     |
| CF.....            | Cystic Fibrosis                                      |
| CFTR .....         | Cystic Fibrosis Transmembrane Conductance Regulator  |
| CFTR2.....         | Clinical and Functional Translation of CFTR Database |
| FEV1.....          | Forced Expiratory Volume in 1 Second                 |
| MAC or NTM.....    | Non-tuberculosis Mycobacterium Avium Complex         |
| MBL.....           | Mannose Binding Lectin                               |
| MSD1 or MSD2.....  | Membrane Spanning Domain 1 and 2                     |
| NBD1 or NBD2.....  | Nucleotide-Binding Domains 1 and 2                   |
| ORCC.....          | Outward Rectifying Chloride Channel                  |
| P. Aeruginosa..... | Pseudomonas aeruginosa                               |
| TGF- $\beta$ ..... | Transforming Growth Factor Beta                      |

## INTRODUCTION

Cystic fibrosis (CF) is a life threatening autosomal recessive disorder, caused by a defect in the CFTR (Cystic Fibrosis Transmembrane Conductance Regulator) gene [1]. The CFTR gene codes for a cAMP (cyclic adenosine monophosphate) dependent chloride channel at the apical epithelial cell surface, which is important for maintaining ion gradients and the subsequent flow of water across membranes in tubular structures [2, 3, 4]. Dysfunction in the CFTR chloride channel can lead to impairment of pulmonary, pancreatic, hepatic, intestinal, and genitourinary system function due to abnormal viscous mucous secretions and fluid flow. These viscous secretions lead to chronic inflammation, tissue damage and the impairment of proper organ function [5]. Clinically, CF is a heterogeneous disorder: patients present with a multitude of symptoms in different organ systems with varying degrees of severity. Approximately 90% of patients are diagnosed in infancy due to pulmonary dysfunction or pancreatic insufficiency, however, the diagnosis of CF can also occur in adulthood [6, 7]. In fact, one case report identified a 70-year-old patient, who had been diagnosed with atypical CF [8]. CF has been found in all racial groups, and is the most frequent life limiting genetic disease in the Caucasian population [3]. More than 30,000 people in the United States have CF [9] and it is estimated that more than 10 million people in the United States are carriers of mutated CFTR [10]. The birth prevalence of CF is one in 3500, and there are approximately one thousand new cases per year [9]. It is estimated that 10% of the thousand CF cases diagnosed per year are in adolescents and adults [7].

Andersen published the first clinical description of CF in 1938, describing infants suffering from malabsorption and pancreatic fibrosis who developed pulmonary dysfunction with age [3, 11]. Diagnosis of CF in the early 1900's was based entirely on clinical symptoms and the life expectancy was approximately six months [4]. A diagnostic breakthrough for CF occurred in 1959, when Gibson and Cooke developed the sweat chloride test for CF, after Darling and co-workers noted that patients suffering from CF have a higher than normal concentration of sodium and chloride in their sweat [12]. In 1985, Knowlton mapped the genomic location of the CF locus to chromosome seven [13], and Rommens published a physical map of the region on chromosome 7 where the cystic fibrosis gene locus was located [14]. This led to the discovery by Riordan, in 1989, who published the genomic sequence of the CF locus, and postulated that the gene product, CFTR, was a transmembrane protein, believed to contain ATP binding domains [15]. Riordan also identified the first known CFTR mutation, the F508 deletion (deletion of a phenylalanine residue at codon 508), in this same paper [15]. Today, there are more than 2000 mutations of the CFTR gene identified in the CFTR2 (Clinical and Functional Translation of CFTR) Cystic Fibrosis database [16]. The first discovered mutation turned out to be the most common mutation associated with CF: 87% of CF patients are heterozygous for the F508 deletion mutation, and 46.5% of CF patients are homozygous for the F508 deletion [17]. Originally it was thought that there would be a clear relationship between a patient's CF genotype and their clinical phenotype. However, much to the dismay of clinicians and scientists, the mechanism that determines CF severity is more complex. There are numerous genetic modifiers and

environmental factors that regulate the expression and severity of the clinical CF phenotypes [18].

A classical case of CF is described as a monogenic disorder resulting from two CF mutations [18]. A patient typically presents prior to age two with a clinical triad of symptoms including chronic sinopulmonary infections, steatorrhea (high fat content in stool), and failure to thrive [18]. Approximately 85% of CF patients are pancreatic insufficient due to a loss of pancreatic exocrine function resulting in malnutrition [18]. If untreated, death is likely within the first decade of life [5]. However, if a patient is treated with pancreatic replacement enzymes and proper respiratory therapies, the median survival age in a classical CF case is now 41.1 years [9]. Obstructive lung disease is the primary cause of death in over 80% of classical CF cases [19].

While there is usually no debate over a classical CF diagnosis, since the 1960's physicians have described a group of patients with less severe symptoms believed to have a different form of CF [4, 20]. Unlike patients' suffering from the classical phenotype, these patients usually have one severe CF mutation on one chromosome, and one less common, mild CF mutation on their other chromosome; or one severe mutation of CFTR on one chromosome, and an abnormal number of trinucleotide repeats in the CFTR gene on their other chromosome [4, 6, 18, 21]. These patients, described in the literature as suffering from non-classical CF, late onset CF, CFTR- related disease, or atypical CF, represent a diagnostic challenge for physicians, and are often misdiagnosed [4]. Patients suffering from atypical CF usually only have one organ system that is dysfunctional, and their clinical symptoms may be less severe than those of a classical case where there are

two severe CF mutations [3, 4, 6, 22, 23]. Symptoms include bronchiectasis, chronic sinus disease, congenital bilateral absence of the vas deferens (CBAVD), and idiopathic pancreatitis [24, 25]. Further, unlike in classical disease, patients with atypical CF are generally pancreatic sufficient [24]. Patients with atypical CF are often not diagnosed until adolescence or adulthood [18, 20] due to the fact that the clinical symptoms in an atypical CF case develop and worsen over time [26]. This makes early diagnosis difficult [27].

Although a patient diagnosed with atypical CF has a longer life expectancy and less severe clinical outlook than a patient with classical CF [22], early diagnosis at the onset of symptoms is imperative in yielding a good clinical outcome for patients. A delay in the diagnosis of atypical CF can result in hospital admissions and morbidity that otherwise could have been avoidable [4, 28]. Patients with atypical CF can be treated with chest physiotherapy, antibiotics, dietary modifications, and pancreatic enzyme replacements [3] that can slow the worsening of symptoms, and yield a favorable clinical outcome. With that said, the long-term outcome and life expectancy is unknown for patients suffering from atypical CF [4].

The purpose of this review is to summarize the current literature on the atypical form of CF in order to increase physician awareness and knowledge of atypical CF and decrease the number of missed diagnoses of atypical CF, thereby improving patient outcomes. The CFTR transporter structure and function and common mutations in both classical CF and atypical CF will be described so that a clinician can make sense of a mutation found in one of their patients; the signs and symptoms of atypical CF will be

described in detail and compared to those of classical CF; a case study will be presented to illustrate the difficulty in diagnosis as well as the diagnostic tools available, and finally current and future management options will be discussed.



## **PART 1: THE CFTR TRANSPORTER**

### **A) CFTR Protein Structure:**

The CFTR gene (OMIM 219700) is located at 7q31.2 and encodes a chloride channel at the apical cell surface, which is regulated by cAMP dependent phosphorylation [2]. The CFTR gene is comprised of 27 exons, which encodes a 6.5 kb mRNA transcript [29]. Dysfunction in the CFTR protein can cause the CF phenotype, or phenotypes other than CF [5]. The CFTR protein channel is a 1480 amino acids membrane spanning glycoprotein with a molecular weight of 170,000 kDa, and is a member of the ATP binding cassette superfamily [30]. The protein contains three primary motifs: two membrane-spanning domains (MSD1, and MSD2), two nucleotide-binding domains (NBD1, and NBD2), and a regulatory domain (R) [5]. The two membrane spanning domains are connected via a nuclear binding factor, which binds to ATP, and a regulatory region [30]. The regulatory region is unique in that it is not found on other members of the ABC superfamily [30]. A simplified illustration of the structure of the CFTR protein channel is depicted in **Figure 1** along with brief description of the roles of the important structures.

*Figure 1: CFTR Protein Structure*

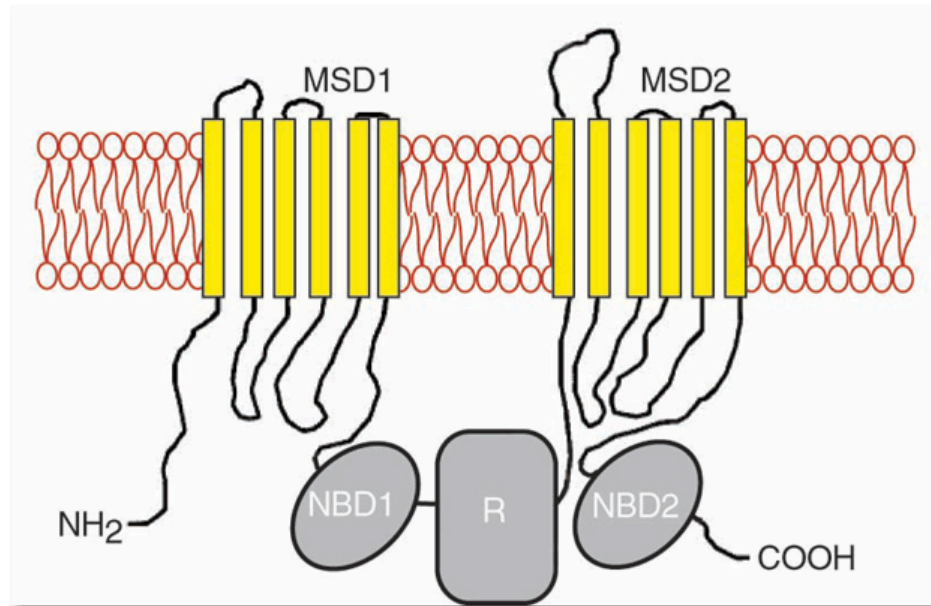

Image created by [30]:

<http://www.genet.sickkids.on.ca/CftrDomainPage.html?domainName=NBD1>

Note: the cell cytoplasm is located on the inferior portion of the depicted membrane and the extracellular fluid is located on the superior portion of the membrane.

*R Region:* Is encoded by exon 13 of the CFTR gene and contains cAMP dependent Protein Kinase A or C phosphorylation sites [30]. The channel opening probability depends on phosphorylation of the R region and on binding of ATP to NBD1 and NBD2 [5, 30]. Amino acid residues 590 to 831 make up the R region [30].

*NBD1 Region:* This region binds to and hydrolyzes ATP, and controls the gating of the channel. Many CF causing mutations are located in this region. For example, the F508 deletion mutation is located here [30]. Amino Acid residues 433 to 584 make up the NBD1 region [30].

*Transmembrane Domains:* Two membrane spanning domains, each with six membrane-spanning regions, form the pore of the channel and subsequently regulate pore function. There are six positive charged amino acid residues within each transmembrane region [30]. Mutations in this region can lead to CF. For example, the R334Q/W mutation and R347L mutation are found in the first transmembrane domain [30]. The first membrane spanning region is made up of amino acid residue's 82 to 351 and the second membrane spanning region is made up of amino acid residue's 880 to 1149 [30].

## **B) The Basic Problem – How Dysfunctional CFTR Causes Problems:**

Dysfunction in the CFTR chloride channel leads to abnormal viscous secretions and fluid flow in tubular organs including the lung, pancreas, liver, gastrointestinal tract and genitourinary system. Here, the mechanism of disease is explained in the lung and the pancreas—the two most prominent organs affected by CFTR mutations.

### *1) Mechanism of lung dysfunction due to defective CFTR:*

Obstructive lung disease, due to chronic or repeated bacterial infections, inflammation, bronchiectasis (enlargement of walls of bronchi), or eventual lung fibrosis is the primary cause of death in 80% of all CF cases [5, 29]. Defective CFTR leads to decreased chloride ion transport and an increase in sodium transport, leading to a net increase in the absorption of water via the paracellular pathway across respiratory epithelium [29]. Summarized in **Figure 2**.

CF most directly affects the upper respiratory tract, or the conducting portion of the lung. The epithelium of the upper respiratory tract is made up of a ciliated respiratory epithelium, containing low columnar or cuboidal shaped ‘club’ cells, which secrete a serous fluid, which traps particulates in the lung [31]. Together, the ciliated epithelium and secreted mucous protect against bacterial infection. The cilia beat at about 1000 times per minute in a coordinated manner to move the secreted mucus upward and out of the upper respiratory tract toward the pharynx [29].

As described in the prior section, the CFTR channel is activated by both the binding of ATP to NBD1 and NBD2 and by the phosphorylation of the regulatory domain. This allows chloride ion flow across the apical surface of the epithelium.

Activated CFTR also regulates other channels on the apical surface of the membrane. König, et al showed that active CFTR chloride channel inhibits the Epithelial Sodium Channel [ENaC] in the apical cell membrane [32]. In cystic fibrosis, where CFTR is dysfunctional, the ENaC channel is activated, and thus the cell absorbs more sodium and further stimulates the sodium potassium ATPase located on the basolateral membrane, which subsequently creates a net driving force for water absorption across the cell via the paracellular pathway [32]. In CF, there is a two to three fold increase in the net absorption of sodium across the respiratory epithelium [29]. This leads to a drier airway surface due to increased water absorption and to the impairment of proper cilia movement, which serves to clear out particulates and bacteria in the upper respiratory tract. The lung is now predisposed to infection, inflammation, bronchiectasis and fibrosis [29].

CFTR also has numerous other functions within the epithelial cell that likely contributes to clinical CF symptoms. CFTR regulates phagosome acidification in macrophages, and thus alters the bacteriocidal activity of the innate immune system [33]. It also modulates ORCC (Outward Rectifying Chloride Channel) activity by an autocrine mechanism involving ATP [34]. Thus, activation of wild type CFTR can lead to further chloride ion transport across the apical membrane by the additive effect of activation of the ORCC. CFTR also regulates vesicle transport within cells, and regulates ATP superfamily channels [1].

*Figure 2: Wild Type versus CF CFTR Ion Transport in Respiratory Epithelium:*

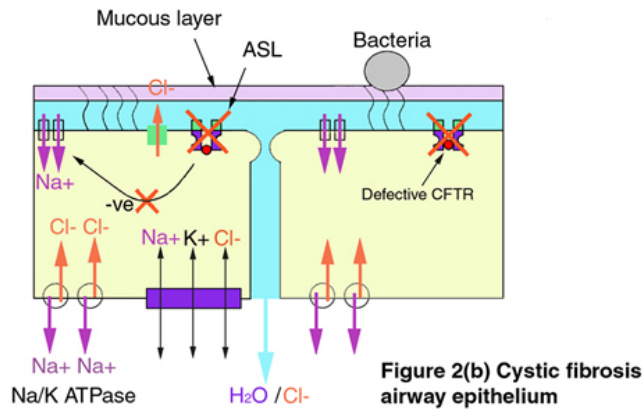
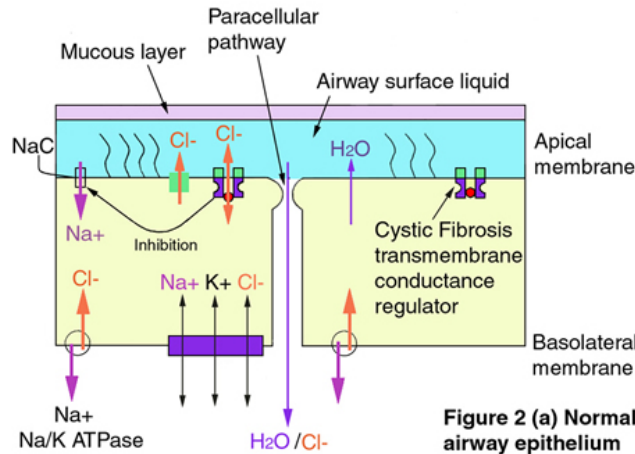

© cysticfibrosismedicine.com

Image adapted from CFmedicine.com [29]. In the upper image, wild type CFTR allows for proper ion balance and the maintenance of normal mucociliary clearance. Active CFTR inhibits the ENaC channel, maintaining the correct osmotic gradient so that the watery ‘sol’ layer (denoted with blue color) above the apical epithelium allows for proper movement of cilia [29]. The airway surface remains hydrated and proper mucociliary clearance occurs.

In the lower image, CFTR is mutated and is nonfunctional. ENaC is activated and sodium absorption is increased two to three fold leading to an increase in water absorption from the ‘sol’ layer above the apical epithelium. The ‘sol’ layer becomes dehydrated, and the cilia cannot beat efficiently [29]. Proper mucociliary clearance is inhibited and bacteria accumulate in mucous layer leading to infection and inflammation.

## *2) Mechanism of Pancreatic Dysfunction Due to Defective CFTR:*

The majority of patients suffering from classical CF are also pancreatic insufficient due to loss of pancreatic exocrine function. This leads to malnutrition secondary to the inability to digest food. **Figure 3**, shown on the following page, presents a schematic of the ion channels present in a human pancreatic duct cell.

Normally, the CFTR channel in pancreatic duct cells will permit chloride ion that entered the cell via the luminal chloride/bicarbonate anti-porter to diffuse back to the lumen. The diffusion of chloride ion back into the lumen makes the luminal potential more negative than the basolateral border, causing interstitial sodium to move through paracellular pathway through the duct cells into the lumen [36]. Further operation of the chloride/bicarbonate anti-porter leads to a build up of bicarbonate and sodium movement into the lumen. Water follows the ion movement into the lumen, creating a large volume of an alkaline solution.

In CF, the chloride channel is non-functional. This prevents the creation of a large volume of alkaline  $\text{NaHCO}_3$  fluid and causes protein aggregation and blockage of the ductal lumen [36]. The lower volume of alkaline fluid produced in the absence of CFTR cannot flush mucus and the protein aggregates out of the ducts [36]. Thus, enzymes are not secreted into the small intestine to facilitate proper digestion, which leads to malabsorption. Pancreatitis occurs if trypsin is activated in the pancreatic duct, which results in the activation of other precursor digestive enzymes [36].

Figure 3: Pancreatic Duct Cell and CFTR [35]

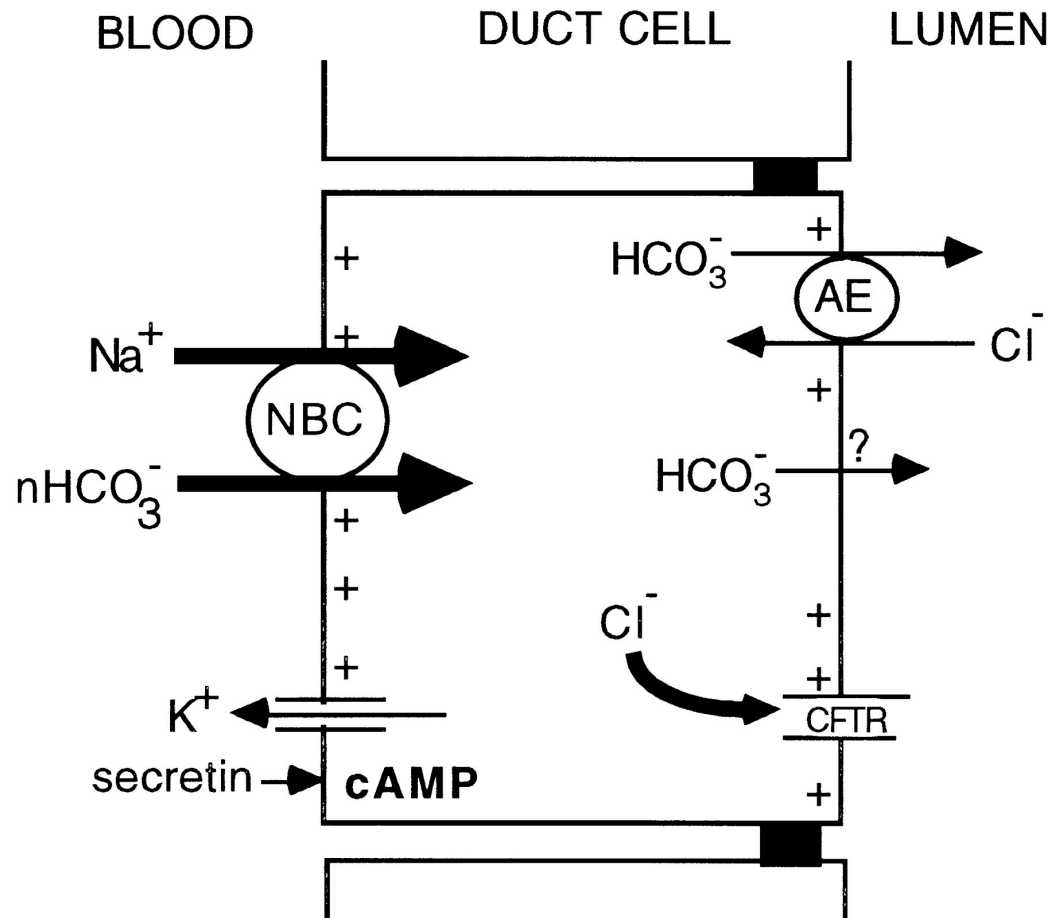

Image provided by <http://ajpcell.physiology.org/content/276/1/C16> [35]

A schematic of the ion transporters present in human pancreatic duct cells is displayed above.

### **C) Mutations in the CFTR Gene:**

As of August 2015, more than 2,000 mutations in the CFTR gene have been entered into the CFTR2 database, comprising of data from 88,664 patients [16]. According to Cutting in his 2014 review of cystic fibrosis genetics: 40% of CFTR mutations are a result of a substitution of a single amino acid; 36% of CFTR mutations alter mRNA processing due to a nonsense, frameshift, or splice sequence alteration; 3% of CFTR mutations involve a large rearrangement of the CFTR gene; 14% of variants are neutral variants and do not cause CF; and 6% of CFTR mutations have an unclear effect [5].

The CFTR2 database classifies mutations in CFTR as either CF causing, non-CF causing, a mutation of varying clinical consequence, or a mutation with an unknown clinical effect [16]. Mutations in CFTR are considered CF causing by the Cystic Fibrosis Foundation if they fulfill one of the following criteria: they must (1) change the sequence of CFTR in a way that affects protein synthesis and function; or (2) introduce a termination sequence via a mutation; or (3) change an intron splice site; or (4) form a new amino acid sequence that is not present in gene carriers of patients ethnic group [37].

In the literature, six classes of CFTR mutations are described. A summary of these mutations is listed in **Table 1**.



*Table 1: Summary of CFTR Mutation Classes*

|                  | Class I  | Class II                                     | Class III                                  | Class IV                         | Class V                             | Class VI                             |
|------------------|--|--|--|----------------------------------|-------------------------------------|--------------------------------------|
| Defect in CFTR   | Defective protein synthesis resulting in no functional protein | Protein is not trafficked to apical membrane | Regulation of Channel opening is defective | Defect in Conductance of Channel | Decreased Functional CFTR Synthesis | Decreased Membrane Stability of CFTR |
| Type of mutation | nonsense, frameshift, splice variant                           | missense, deletion                           | missense, AA change                        | missense, AA change              | Splicing variant, missense          | missense, AA change                  |
| Example          | G542X  | F508del                                      | G551D                                      | R117H                            | 5T allele                           | Q1412X                               |

Table generated with information from [3, 18, 38]

Although widely accepted in the CF literature, these classifications have been criticized because certain mutations have varying effects and can fit into multiple categories. For example, the F508del mutation, which is an out of frame deletion of -CTT- nucleotides [39] causes: 1) a low membrane residency of CFTR (Class VI mutation) [5]; 2) a silent codon change (ATC->ATT) in the triplet that encodes isoleucine at codon 507 [39], leading to a decrease in translation efficiency (Class V); and 3) disrupts proper CFTR trafficking to the membrane (Class II) [5].

To get classical CF a patient must have two severe mutations which are usually considered as class I, II or III [17]. Patients with atypical CF typically have one severe mutation and at least one mild mutation typically of class IV or V, that allows for the residual function of CFTR -thus, their disease is not as severe [7]. It is accepted that patients with less than 1% of wild type CFTR function have the classical form of CF characterized by pancreatic insufficiency and chronic pulmonary infections [40]. Patients with less than 4.5% of wild type CFTR function display symptoms of progressive pulmonary dysfunction, and patients with less than 5 percent of wild type CFTR function have a sweat chloride measurement abnormality [40]. Less than 10% of wild type CFTR results in the CBAVD in males [40]. Currently, researchers with CFTR2 are developing a computer algorithm to match CF genotype to disease symptoms [16].

To illustrate the differences in genotype between classical CF and atypical CF, a 2005 study by Rodman [41] compared the genotype distribution of 55 patients that were either diagnosed early in life (below age 15) with CF or diagnosed with CF later in life (age greater than 24). All of the patients in the study were older than 40. The genetic

distribution of the patients is shown in **Table 2**. Note that patients in the late diagnosis group had a higher prevalence of class III-V mutations and unidentified mutations, and that homozygous individuals were more common in the early diagnosis group.

Rodman's observations are also supported in a study by Nick, who found that 70% of long surviving patients had one residual function (class IV or V) mutation [11]. The results of Rodman's study indicated that patients in the late diagnosis group had clinical symptoms that were milder, and indicative of atypical CF. Another interesting finding not indicated in the table was that the majority of patients in the late diagnosis group were female [41].

Table 2: Genotype Distribution in Patients with Early and Late Diagnosed CF [41]

**TABLE 1. GENOTYPE DISTRIBUTION**

|                    | Early Diagnosis | Late Diagnosis |
|--------------------|-----------------|----------------|
| ΔF508/ΔF508        | 10              | 1              |
| ΔF508/ΔI507        | 1               |                |
| ΔF508/G551D        | 1               |                |
| ΔF508/M1101K       | 1               |                |
| ΔF508/P67L/11027T  | 1               |                |
| ΔF508/3120G-A      | 1               |                |
| ΔF508/2789+5G-A    | 1               | 2              |
| ΔF508/W1282X       | 1               |                |
| ΔF508/621+1G-T     | 1               |                |
| ΔF508/R347P        | 1               |                |
| ΔF508/3849+10kbC-T | 1               | 1              |
| ΔF508/A455E        |                 | 2              |
| ΔF508/R347H        |                 | 2              |
| ΔF508/D1152H       |                 | 1              |
| Δ508/I148T         |                 | 1              |
| ΔF508/R117H        |                 | 1              |
| ΔF508/Y109N        |                 | 1              |
| ΔF508/IVS8-5T      |                 | 1              |
| ΔF508/unknown      | 3               | 5              |
| S1251N/D1152H      |                 | 1              |
| G542X/R117C        |                 | 1              |
| R117H/G551D        |                 | 1              |
| W1282X/D1152H      |                 | 1              |
| Unknown            | 4               | 4              |

Values represent number of individuals in each diagnostic group with each genotype.

Aside from the specific mutations in CFTR themselves, some mutations may be made more or less severe depending on a genetic variant located on the same chromosome [40]. One example is the poly-thymidine tract in intron 8, which is situated near the splice site on exon 9 [42]. Three variants exist, including the 5T, 7T and 9T alleles [40]. Variation in the number of thymidine nucleotides can result in a decreased amount of normal CFTR mRNA [42]. The 5T allele is the most severe of the three mutations, and the 9T allele maintains the most function at the splice site [42]. These genetic variations of the poly-thymidine tract are particularly important in atypical CF. For example, the R117H mutation clinical phenotype depends on what poly-thymidine

allele is present. When R117H is on the same chromosome as the 7T allele, a patient will likely have adult diagnosed CF, pancreatic sufficiency, and either mild or chronic lung disease [7]. However, when R117H and the 7T allele are on opposite chromosomes, a patient may experience mild CF or no symptoms at all [7]. In this case, other factors such as genetic modifiers or the environment likely contribute to the development of CF disease like symptoms.

#### **D) Genotype-Phenotype Correlation and Variation in Disease Severity:**

Upon the initial discovery of the CFTR gene in 1989, it was thought that the phenotypic variability of symptoms observed in CF patients would be entirely attributed to the allelic heterogeneity in the dysfunctional CFTR gene [43]. The scientists who originally discovered CFTR also thought that there could be as many as 10 mutations [44]. Both predictions turned out to be false.

The clinical possibilities of a patient with two CFTR mutations are immense: Some possibilities include: (1) patients who have no symptoms of CF and normal sweat chloride levels, (2) patients with classic CF symptoms, (3) patients with sinopulmonary disease, positive sweat chloride tests and pancreatic sufficiency, (4) patients with sinopulmonary disease, normal sweat chloride tests, and male fertility, (5) patients whose only symptom is male fertility, (6) patients with chronic sinusitis and CBAVD, (7) patients with chronic pancreatitis only, (8) patients with positive sweat chloride tests only, and no symptoms [44]. With this variety of presentations, it is no surprise that diagnosis of the atypical presentations of CF is difficult. A possible conclusion that can be drawn from the variety in clinical presentations is that although CF is a disorder

caused by a single gene, its clinical presentation resembles that of a polygenic disorder [44] and that genetic modifiers and environmental factors likely play a large role in determining the severity of CF symptoms.

Although CFTR genotype correlates with the overall severity of pancreatic exocrine disease, and to sweat chloride levels [45, 46], genotype does not correlate with pulmonary disease severity [45, 47]. To attempt to elucidate links between pulmonary disease severity and genotype, the European CF Twin and Sibling Study, compared affected monozygotic twins to affected dizygotic twins. It was found that CF affected monozygotic twins had a significantly lower DELTA value (a parameter used by the researchers to define disease severity) than dizygotic pairs, suggesting that CF disease severity is modulated by an inherited component (genetic modifier) in addition to the gene itself [48]. In another study using affected monozygotic twins and sibling pairs, it was found that 50% of the variation in pulmonary function between twin and sibling pairs could be attributed to genetic modifiers, while 36% of variation could be explained by environmental factors unique to the individual, and 14% to shared environment [49]. Thus, genetic modifiers and the environment likely affect the severity of CF pulmonary disease.

### **E) What are the Genetic Modifiers?**

Genetic modifiers are genes not found within the CFTR gene, which modify the expression of the CFTR gene. Some genetic modifiers to clinical CF phenotypes are presented below, however, many more have been identified in the literature and more are being discovered every year.

1) A major determinant of CF lung disease severity is inflammation, and it is likely that the inflammatory system influences the pulmonary phenotype in those who have CF [50]. One possible effector is TGF $\beta$ -1 (transforming growth factor  $\beta$  1). Polymorphisms of the TGF $\beta$ -1 gene have been shown to lead to variations in cytokine levels and are linked to fibrosis in various tissues [51]. In one study by Arkwright, patients with CF and a high producing TGF $\beta$ -1 genotype had more pronounced deterioration in lung function than those with the low TGF $\beta$ -1 producer genotype [51].

Another example of a possible effector of inflammation is mannose-binding lectin (MBL), which is a component of the innate immune system. One study found that the presence of the MBL variant allele is associated with poor prognosis and early death in patients with CF [52]. Another study showed that MBL variant alleles may make some CF patients more susceptible to recurrent infections, and that lung function in patients with the MBL variant allele may be reduced compared to wild type [53].

2) Colonization of lungs by *Pseudomonas aeruginosa* is associated with reduced survival in CF patients and is considered a hallmark of progressing lung disease [5]. A study by Green showed that genetic factors influence the age at the establishment of chronic infection with *Pseudomonas aeruginosa* [54].

3) Meconium ileus (MI) is an obstruction of the small intestine, and is found in 10-15% of CF patients in utero or in early neonatal period [44]. There is evidence of a modifier locus for MI on chromosome 19q13, providing evidence that there is a gene that predisposes a carrier to have meconium ileus in combination with CF [55].

4) For patients with classical CF, poor growth is caused due to pancreatic exocrine dysfunction. Although replacement enzymes can be administered there is still a cohort of patients with a low BMI even with therapy [5]. Genetic control of BMI without considering the effect of CFTR seems to be important in this case [5].



## **PART 2: CF AND ATYPICAL CF SIGNS AND SYMPTOMS**

Clinical symptoms of both classical and atypical cystic fibrosis are largely restricted to the respiratory, gastrointestinal, endocrine, and genitourinary tracts. Symptoms are broken down by organ system for classical CF, and atypical CF, respectively, so that one can compare the two presentations of the disease. A discussion of frequent mutations associated with clinical symptoms of atypical CF is also included.

### **Classical CF:**

Patients suffering from classical CF tend to present prior to age two with a clinical triad of symptoms including chronic sinopulmonary infections, steatorrhea, and failure to thrive. Classical symptoms are associated with two severe class I-III CFTR mutations on two separate chromosomes.

*1) Symptoms in the respiratory tract:* Respiratory symptoms are the primary association a physician has with CF Fibrosis for good reason; pulmonary dysfunction contributes to 80% of CF mortality and morbidity [5]. Symptoms associated with classical CF include the following: chronic or recurrent sinopulmonary infections, colonization of lungs by *pseudomonas aeruginosa*, bronchiectasis, nasal polyposis, refractory asthma, and symptoms of progressive respiratory obstruction -- all of which begin in childhood [56]. Interestingly, the presence of digital clubbing is associated to the degree of hypoxemia, and airway obstruction [57].

*2) Symptoms associated with the gastrointestinal tract:* Approximately 85% of classical CF patients are pancreatic insufficient. Symptoms of exocrine pancreas insufficiency include steatorrhea (presence of high fat content in stool), fat-soluble

vitamin deficiency, and difficulty gaining weight [28]. Other symptoms involve liver cirrhosis, and portal hypertension. Approximately 20% of affected children between the ages of 6 months and 3 years suffer from rectal prolapse secondary to malabsorption, elimination of bulky stools, and poor muscle tone [18]. Salt bile depletion syndrome manifested as hypokalemia or metabolic alkalosis has been reported as well as prolonged neonatal jaundice due to intrahepatic bile stasis [18].

3) *Symptoms associated with the genitourinary tract:* Approximately 97 to 98% of men with classical cystic fibrosis suffer from azoospermia in a semen sample due to congenital bilateral absence of the vas deferens (CBAVD) [4, 59, 60]. Women are generally fertile but can experience difficulty in conceiving a child due to thickened cervical mucus [61, 62].

4) *Symptoms associated with endocrine and metabolic organ dysfunction:* In classical CF, patients can suffer from endocrine pancreatic dysfunction. One paper suggests that this can even be the primary presentation of CF [63]. Other symptoms include electrolyte imbalances, which mostly occur due to dehydration or a heat stroke [4, 21].

5) *Other symptoms:* Other symptoms indicative of classical CF include dermatitis caused by nutritional deficiencies, early aqueous wrinkling and angitis [4].

### **Atypical CF:**

Atypical CF symptoms are in general less severe and subtler than the classical CF symptoms associated with the same organ. For atypical cases, it is likely that dysfunction is in only one organ system, and that symptoms worsen over time [3, 4, 6, 22, 23].

Patients suffering from atypical CF usually have one severe CFTR mutation and one mild, residual function CFTR mutation, or one severe mutation along with an abnormality in trinucleotide repeats on their other chromosome [4, 18, 21]. The most common mutation found in adult diagnosed patients with atypical CF is the F508del, followed by R117H, 3849+10kb C to T, and the D1152H mutation [7, 64]. In one study [22] examining the genetics of patients diagnosed with CF in adulthood, there were no homozygous F508del mutations found, but 72% were heterozygous for F508del and 28% had two other mutations aside from F508del. A summary of symptoms associated with atypical CF is located in **Table 3** and the clinical presentation of symptoms at the time of diagnosis broken down by age group is located in **Table 4**.

*1) Symptoms Associated with respiratory tract:* Approximately 70% of patients diagnosed after the age of 18 years initially presented to their clinician with acute respiratory symptoms [64]. Respiratory symptoms associated with atypical CF are generally milder when compared to symptoms of classical CF and may not begin until adulthood (4). Symptoms include recurrent pneumonia, and symptoms involving chronic obstruction of the airways including: COPD, chronic sinusitis, nasal polyposis, idiopathic (cause unknown) bronchiectasis and asthma [4, 18, 7, 65, 66, 67].

Two studies by Rodman [41] and Nick [11] compared the FEV1 (forced expiratory volume in 1 second) measurements at age 40 of patients diagnosed with classical CF as a child to patients who were diagnosed with CF after age 18. Both studies showed that patients diagnosed with CF after the age of 18 (considered atypical CF) had better FEV1 measurements than patients who were diagnosed with classical CF in

childhood. FEV1 values for the childhood diagnosis group were 50% and 40% and FEV1 values for the adult diagnosis group were 57.9% and 60% respectively in Nick's and Rodman's publications [11, 41]. Thus patients suffering from atypical CF likely have less severe lung dysfunction than those suffering from classical CF, but still worsened lung function compared to a non-CF patient.

In 2010, Keating published an article in *Chest* analyzing the CF Foundation Patient Registry for patients diagnosed with CF after age 18 [64]. She found that 16% of patients diagnosed as adults have nasal polyps and sinus disease at their initial presentation. She also found a difference in the types of bacteria that colonize the lung in classical CF and atypical CF cases: for patients less than 12 years old, 27% had colonization with *Pseudomonas aeruginosa*, and less than 0.1% suffered from non-tuberculosis mycobacterium avium complex (MAC) infection, while patients with adult diagnosed patients had 50%, and 5% colonization respectively [64].

2) *Symptoms associated with the GI tract:* GI symptoms are rarer in atypical CF than in classical CF. Symptoms include chronic constipation, diarrhea [4, 65, 68] and recurrent idiopathic pancreatitis with no respiratory symptoms [4, 7]. Patients with atypical CF are also less likely to have steatorrhea [7].

According to multiple studies, patients with atypical CF or adult diagnosed CF are less likely to be pancreatic insufficient than patients with classical CF who were diagnosed in childhood [11, 69, 70]. Nick's study showed that 50% of adult diagnosed patients that lived to at least 40 years had pancreatic sufficiency [11]; thus we cannot rely on pancreatic insufficiency alone for a CF diagnosis in adults [7]. However, idiopathic

pancreatitis, without any other CF symptoms is indicative of atypical CF. According to Boyle [7], 10-15% of patients with idiopathic pancreatitis that do not consume alcohol or have gallstones have a mild form of CF.

3) *Symptoms associated with the endocrine organs:* Diabetes mellitus and electrolyte imbalances are the two symptoms associated with atypical CF [4]. Interestingly, type two diabetes mellitus (T2DM) is associated with rapid decline in lung function in patients suffering from classical CF [5].

4) *Symptoms associated with the genitourinary tract:* As described in the classical symptom section, 97-98% of men with classical CF are infertile due to CBAVD. One in a thousand men suffer from CBAVD in the total population, which is the cause of 1-2% of total male infertility cases [18].

CBAVD presents an interesting case of CFTR genetics: in men with CBAVD alone, 10-20% carry two CFTR mutations, 40-60% carry one CFTR mutation, and 30-50% have no CFTR mutation [6]. CBAVD is typically caused by a residual function CFTR class IV or V mutation, resulting in less than 10% of wild type CFTR function [18]. These mutations are likely splice variants or missense mutations, commonly the 5T allele and the R117H mutation [7, 18, 44, 71]. However, it is interesting that individuals with the same genotype do not necessarily have the same clinical phenotype. For example, for a male individual with one copy of the F508del on one chromosome and the 5T allele on the other chromosome: 40% of the time there will be no disease, 60% of the time only CBAVD will be present, and less than one percent of the time atypical CF will occur [7, 72]. Another study [73] found that patients with CBAVD who were otherwise

normal had an increased likelihood of suffering from mild to moderate respiratory disease. Together the results of these studies suggest that CBAVD is associated with CFTR mutations, with atypical CF and that mild symptoms take time to develop. A prospective study following patients with CBAVD, and two CFTR mutations from their time of diagnosis through their 50's could more closely reveal a relationship between CBAVD and the temporal development of symptoms representative of atypical CF. Genetic modifiers and environmental factors also likely play a role in development of atypical CF in these patients.

In summary, a physician should consider that a patient is suffering from atypical cystic fibrosis if bronchiectasis is observed along with any of the following: idiopathic pancreatitis, CBAVD, MAC infection, *Pseudomonas aeruginosa* infection, allergic bronchopulmonary aspergillosis infection, sinus disease or nasal polyposis [7].

Table 3: Summary of Symptoms associated with atypical CF Adapted from [4, 7 18, 64, 65, 66, 67]

| Organ System  | Symptoms   |
|---------------|--|
| Respiratory   | chronic sinusitis, COPD, nasal polyposis, recurrent pneumonia, idiopathic bronchiectasis, asthma, <i>Pseudomonas aeruginosa</i> colonization, MAC colonization |
| GI            | diarrhea, constipation, idiopathic pancreatitis, weight loss, nutritional deficiency   |
| Genitourinary | CBAVD in males, reduced fertility in females   |
| Endocrine     | Diabetes mellitus, electrolyte imbalances  |

Note that any symptom of CF could be a symptom of atypical CF. The most common symptoms of atypical CF identified in the literature are listed in the **Table 3** above.

Table 4: Clinical Presentations at the Time of Diagnosis. Table adapted from [64].

| Clinical Presentation       | Age < 12 | Age 12-18 | Age > 18 | P Value |
|-----------------------------|----------|-----------|----------|---------|
| Acute respiratory symptoms  | 42.40%   | 64.20%    | 70.60%   | <.001   |
| <a href="#">Other*</a>      | 3.70%    | 11.40%    | 18.10%   | <.001   |
| Nasal polyps/sinus disease  | 2.60%    | 19.30%    | 16.10%   | <.001   |
| Family history              | 16%      | 13.10%    | 15.70%   | <.18    |
| Steatorrhea/abnormal stools | 24.70%   | 23.90%    | 14.60%   | <.001   |

\*Other: Includes idiopathic pancreatitis and male infertility. Patients diagnosed prior to age 12 likely present with the classical form of the disease and patients diagnosed after the age of 18 represent the atypical presentation of CF.

### **PART 3: DIAGNOSING ATYPICAL and CLASSICAL CYSTIC FIBROSIS**

Diagnosis of classical CF is well characterized and is usually undisputed. The CF Foundation Consensus Criteria for Diagnosis includes the following: a patient must exhibit clinical symptoms of CF (listed in prior section), a family history of CF, or a positive newborn screen test for CF [3]. Also, a patient must have evidence of abnormal CFTR function depicted by a sweat chloride level greater than 60mmol/L, a genetic test result showing two mutations in CFTR, or abnormal nasal transepithelial ion transport [3, 44].

A 2006 review article on cystic fibrosis diagnostic algorithms [56] published in Thorax recommends that a physician who suspects that a patient has CF start with a sweat chloride test. A sweat chloride test yields strong evidence for the clinical presence of cystic fibrosis. Traditionally, a sweat chloride value of greater than 60mmol/L is indicative of CF [3,74]. If the sweat chloride value is greater than 70mmol/L, the specificity and sensitivity of the sweat chloride test approaches 100% [75]. Patients with this level of sweat chloride will nearly all have two severe CF causing mutations. However, follow up testing is still recommended until a genetic confirmation can be obtained [74]. Conversely, a sweat chloride value below 39mmol/L is unlikely to be CF [3], and a value between 40-59mmol/L is considered intermediate [74].

It is in a patient who has a sweat chloride level in the intermediate range that could have atypical cystic fibrosis. For these patients, who are usually adolescents and adults that did not receive newborn CF screening, follow up genetic testing and nasal potential difference testing is recommended. Today, these patients make up roughly 10%



of those diagnosed with cystic fibrosis [7]. An article published in *Chest* in 2010 by Keating determined that 8.3% of new CF diagnoses occurred in patients over the age of 18, and that the proportion of CF diagnoses in patients over 18 years of age has been increasing every year [64]. It is likely that this number will continue to rise until all patients born before newborn screening have been diagnosed. According to Keating, 25% of adult patients diagnosed with CF, have indeterminate sweat chloride concentrations [64].

Follow up genetic testing is performed in patients with intermediate sweat chloride levels. Patients identified with two mutations in CFTR on separate chromosomes that are known to cause CF can be diagnosed with atypical CF [56]. In patients with borderline or intermediate sweat chloride levels and one or zero CFTR mutations, nasal potential difference testing is performed [4, 56]. This is because the patient may have a novel CFTR mutation, or a mutation that was not screened for in the genetic test. A flow chart of the process of CF diagnosis is provided in **Figure 4**.

Figure 4: A Diagnostic Algorithm for CF [42]

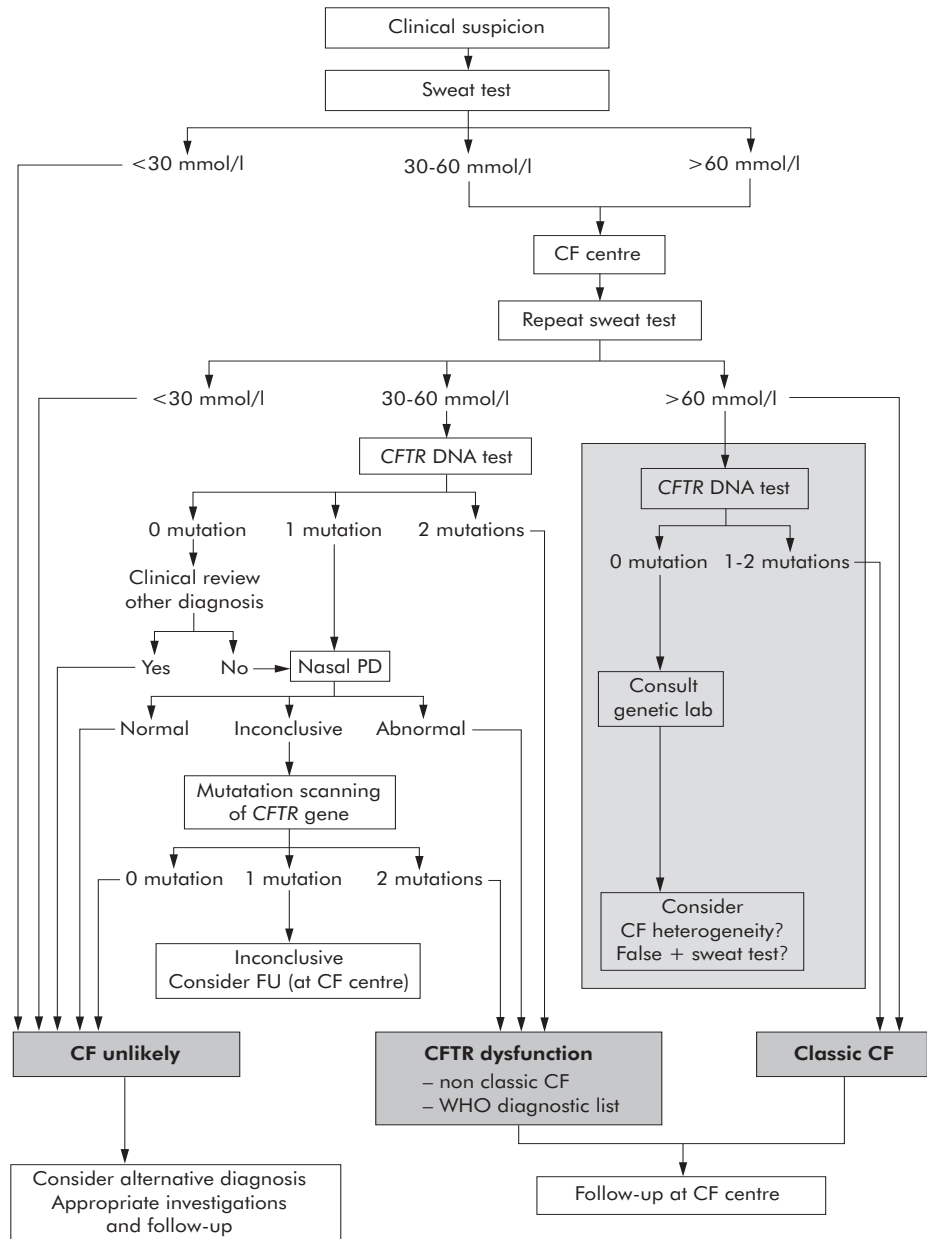

A flow chart depicting the diagnosis of atypical CF starting with a sweat test. Individuals with intermediate sweat chloride test results are tested twice and then tested for genetic mutations in CFTR. If two CF causing mutations are identified, atypical CF can be diagnosed. If only one mutation is identified, a nasal potential difference test is performed. An abnormal result provides evidence for atypical CF diagnosis. If the nasal potential difference test is normal, CF is unlikely.

Nasal potential difference testing can provide evidence to strengthen an atypical CF diagnosis, but is not a definitive test on its own [4]. It is a difficult test to perform and is only available in certain academic medical centers. Like sweat chloride levels, some patients suffering from atypical CF can have intermediate nasal potential difference levels [76]. In CF, the baseline potential difference is more negative than in patients with wild type CFTR [76]. When amiloride, an ENaC channel inhibitor, is added, sodium flow is disrupted and the potential difference increases (becomes more positive). In CF, there is a larger than normal increase in nasal potential difference due to aberrant regulation of the ENaC channel. The nasal mucosa is then washed with a chloride free solution, and lastly, isoproterenol is added. **Figure 5** on the following page shows nasal potential difference tests on a healthy subject with wild type CFTR and a CF case.

Figure 5: Nasal Potential Difference Testing in Normal and CF Individuals [5642]

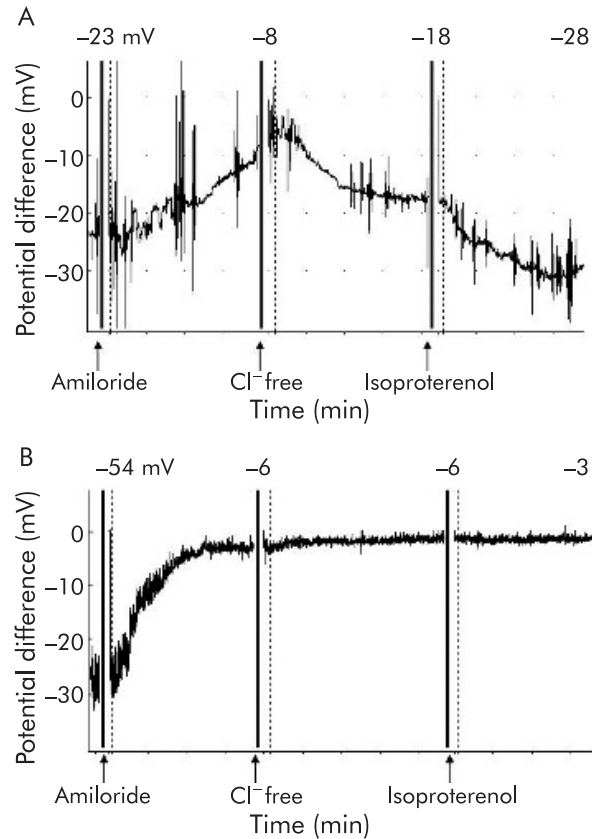

Nasal potential difference testing is shown in a normal individual in A and a CF patient in B. The CF patient has a more negative baseline potential difference than the normal individual. Upon addition of amiloride, the potential difference increases toward zero in CF individuals at a higher rate than in the normal individual. Upon addition of a chloride free solution, the basal potential difference does not change in a CF individual, and decreases (becomes more negative) in a normal individual. Addition of isoproterenol, a  $\beta_1$  and  $\beta_2$ -agonist, leads to an increase in intracellular cAMP and the activation of the CFTR channel. In normal individuals, a decrease in potential difference is seen, while there is no effect on the CF nasal potential difference [3]. In atypical cases, a borderline test result can be observed, with changes that are intermediate in nature between what is expected in a wild type CFTR individual and a CF individual [76]. There is not yet a consensus as to what constitutes a negative result [56].

Figure 5: A Diagnostic Algorithm for CF [56]

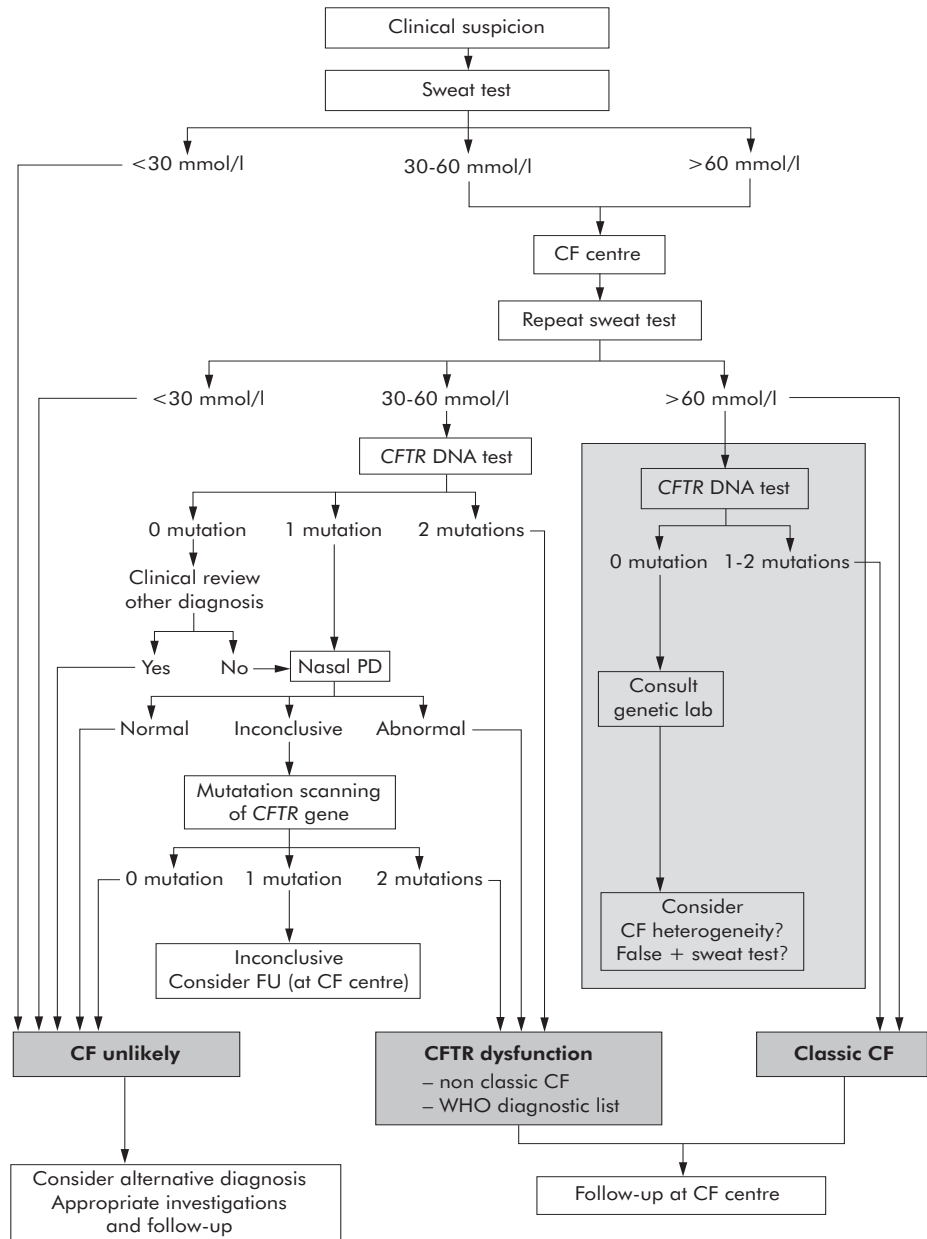

A flow chart depicting the diagnosis of atypical CF starting with a sweat test. Individuals with intermediate sweat chloride test results are tested twice and then tested for genetic mutations in CFTR. If two CF causing mutations are identified, atypical CF can be diagnosed. If only one mutation is identified, a nasal potential difference test is performed. An abnormal result provides evidence for atypical CF diagnosis. If the nasal potential difference test is normal, CF is unlikely. [56]

## **A Case Study: Diagnosis of Atypical CF in a 55-year-old Female:**

In order to emphasize the difficulty that both a patient and physician go through in order to arrive at an atypical CF diagnosis, a case report of a 55-year old female is presented. The patient, denoted patient A, was interviewed, and medical records and radiographic film reports were obtained dating back to 2005.

Patient A's first sign of atypical cystic fibrosis was in 2005 at the age of 49. Patient A was involved in a car accident and transported to a trauma center by ambulance. A chest CT with contrast was performed. On the CT, minor reticular densities in the right middle lobe of the lung, representative of acute or chronic inflammatory disease were observed. Patient A was informed of the findings but suffered no respiratory symptoms, and did not follow up further.

In 2007, patient A began allergy shots to control allergic symptoms to grasses and oak trees. She reports going through a turning point, where she became ill for a one-month period with a worsening cough. Patient A sought out her primary care physician who prescribed antibiotics. The exact antibiotic is unknown, as the chart from this physician was unable to be obtained. Although her initial fever subsided, patient A reported no change in the developing cough. Patient A followed up with her allergist who diagnosed her with adult onset asthma.

In 2011, patient A's cough was still worsening. Patient A sought out a local pulmonologist to attempt to control her cough. The pulmonologist ordered another chest CT with contrast. Findings of the chest CT included an increase in tiny centrilobular nodules in the middle and lower right lung, and a 5mm nodule in the upper lobe of the

left lung. Mild scarring and bronchiectasis was present in the right middle lobe. The pulmonologist obtained sputum samples and one sample came back positive for non-tuberculosis mycobacterium avium complex (MAC), which is associated with atypical cystic fibrosis. The pulmonologist also ordered blood labs, and patient A was found to have a low neutrophil count, but was otherwise normal. Patient A was diagnosed with MAC and bronchiectasis without acute exacerbation and prescribed 500mg azithromycin to be taken 3 times per week, and a flutter valve to aid in clearing mucus. Patient A reports taking azithromycin for over one year.

In 2012, patient A continued to have a persistent, chronic cough and was referred by her pulmonologist to an infectious disease specialist at a regional academic medical center. Patient A gave sputum samples, which were tested for the following: yeast or fungal elements, acid-fast bacillus, *Staphylococcus aureus*, and *Haemophilus parainfluenzae*. Few *Haemophilus parainfluenzae* (beta lactamase negative) and *staph aureus* were found. All other tests were negative. Patient A was also tested for IgG subclasses 1-4 and IgE levels, all of which were within normal ranges. She was also tested for allergic bronchopulmonary aspergillosis (ABA), and was negative. After exhausting diagnostic tests, the infectious disease physician referred patient A to one last specialist the Chest Clinic at the same medical center. Patient A was given a sweat chloride test, which yielded an intermediate level result of 54mmol/L. Genetic testing was performed and patient A was found to be heterozygous for F508del and compound heterozygous for the 7T and 9T allele. A diagnosis of atypical cystic fibrosis was made. Patient A was prescribed a sodium chloride 7% inhalation solution to be used with a

nebulizer, an albuterol inhaler, and mometasone/formoterol (an inhaler with long acting beta 2 agonist and corticosteroid) to control her pulmonary symptoms and omeprazole for heartburn. Under proper management, a 2015 chest CT with contrast showed no new nodules in Patient A's lungs. However, despite pharmacological intervention and a diagnosis, patient A still suffers from a debilitating chronic cough at all times of the day.

Patient A's diagnosis of atypical cystic fibrosis was missed by a general practitioner, an allergist, a pulmonologist and an infectious disease doctor. Patient A reports that her current specialists have told her that she likely would have never been diagnosed had she not come to a chest clinic at a regional medical center. In CF lung disease, the earlier the diagnosis, the better the outcome. Would patient A suffer from as debilitating a cough as she currently does with an earlier diagnosis and with proper disease management? Would multiple antibiotics have made a difference in her initial treatment of non-tuberculosis mycobacterium avium complex (NTM or MAC) bacteria? Evidence in the CF literature says yes to the first question, and is inconclusive on the second. Further, with the advent of new molecular therapies for CF treatment, patients with atypical CF are poised to benefit immensely. But, we cannot administer the drug if we cannot identify the disease first.



#### **PART 4: TREATMENT OF ATYPICAL CF**

While the treatment regimen for classical cystic fibrosis is well defined, to date, no study focused entirely on the proper standard of care for a patient with atypical CF can be found via a PUBMED search. Luckily for patients diagnosed with atypical CF, most of the current CF management principles apply. However, patients with atypical CF are different from patients with the classical form of the disease and require an individualized treatment approach that depends on the severity of their symptoms and genotype [7]. Managing an atypical CF case in the same manner, as a classical CF case could possibly be too aggressive, however, a subset of patients with severe disease, diagnosed later in life may benefit from aggressive management.

As with classical CF, lung infections and pulmonary exacerbations can be treated with a plethora of different antibiotics [58] depending on whether the infection is due to *pseudomonas aeruginosa*, non-tuberculosis mycobacterium avium complex (denoted as MAC or NTM), or another bacteria. Chest physical therapy, a flutter valve type instrument and inhaled hypertonic saline can be used to dislodge mucus in the airway [58, 77]. Pancreatic enzyme replacement therapies can be administered in a rare case of malabsorption in atypical CF. Lung transplant, although an option in classical CF, is generally not indicated for atypical CF lung disease. The survival rate two years after a lung transplantation is between 60 and 65% for all patients [78] – thus a lung transplant is likely too aggressive for nearly all patients suffering from atypical CF. A joint statement by the American Society for Transplant Physicians, American Thoracic Society, European Respiratory Society and Society for Heart and Lung Transplantation

recommended lung transplantation only in CF patients with a FEV1 of less than 30% of predicted or a rapid decline in lung function [98].

While all of above therapies are helpful in treating the symptoms of the disease, they do not treat the underlying cause of the disease. Patients with atypical CF are, however, in an optimal position to reap the benefits of the research to create molecular therapies treating the underlying cause of the classical form of CF. To date, two drugs that target the molecular basis of CF have been approved for the FDA, and more are in the pipeline. Depending on a patients genotype, these drugs could already have a beneficial impact to a patient with atypical CF. In this section, the traditional therapies for classical CF that are applicable to atypical CF, and the new molecular therapies that could be used to treat the atypical form of the disease will be discussed.

### **1) Traditional Therapies to Treat Pulmonary Atypical CF Symptoms:**

Traditional CF therapies that have an impact on lung function include antibiotics, bronchodilators, chest physical therapy, inhaled hypertonic saline, mucolytic agents, and orally administered non-steroidal anti-inflammatory drugs (NSAIDS). As recommended by the Cystic Fibrosis Foundation (CFF), the current order of administration of inhaled therapies is a bronchodilator; followed by inhaled hypertonic saline solution administered via nebulizer; followed by dornase alpha, followed by airway clearance, and then an aerosol based antibiotic [79]. A summary table created by the Cystic Fibrosis Foundation in 2013 of treatment options for pulmonary symptoms is included in **Table 5** at the end of the section.

*Antibiotics:*

Antibiotics are used to treat acute deteriorations in pulmonary exacerbations as well as bacterial infections in classical CF [58]. According to a Medscape review, the antibiotics (AB) used in CF patients to treat *Pseudomonas aeruginosa* include the following: inhaled tobramycin, or intravenous tobramycin with a penicillin based AB; inhaled aztreonam; gentamycin in combination with a penicillin based AB; piperacillin; cephalexin; ceftazidime; ciprofloxacin; trimethoprim, and chloramphenicol [80].

A 2013 review by the Cystic Fibrosis Foundation (CFF) on current pulmonary treatments in CF recommends that patients suffering from mild lung disease and persistent *pseudomonas aeruginosa* infection should be prescribed daily inhaled aztreonam or tobramycin therapy in order to reduce pulmonary exacerbations, and improve quality of life [79]. Note that the CFF considers mild lung disease as a patient with 70-89% of predicted FEV1, moderate lung disease as a patient with 40-69% of predicted FEV1, and severe lung disease as a patient with less than 40% of predicted FEV1 [79]. For patients suffering from moderate to severe disease, inhaled aztreonam is the first line of therapy. In patients suffering from mild disease, one clinical study by Wainright found that thrice daily administration of inhaled aztreonam over 28 days in 157 patients led to a 2.7% improvement in FEV1 over placebo and a modest improvement in quality of life [81].

The CFF also recommended azithromycin for the treatment of persistent *pseudomonas aeruginosa* infection in airway cells based upon evidence found in four clinical trials finding that azithromycin decreased pulmonary exacerbations in patients

with CF. A Cochrane Review [82] supports this recommendation by the CFF, concluding that azithromycin is effective in decreasing pulmonary exacerbations, and increasing FEV1. Researchers with the CFF, did note that chronic usage of azithromycin may lead to non-tuberculosis mycobacterium infection (NTM), and recommended that patients be screened for NTM prior to beginning an azithromycin regimen [79]. The CFF also found that chronic administration of azithromycin should be considered in patients without *pseudomonas aeruginosa* infection to reduce pulmonary exacerbations [79].

To treat non-tuberculosis mycobacterial infection (NTM), the drug regimen of choice and length of time antibiotics are needed varies. One review by the American Thoracic Society recommended that non-tuberculosis mycobacterial disease in patients with nodular or bronchiectatic disease be given a three times per week regimen of clarithromycin, or azithromycin (a macrolide AB) for one year or until a non-tuberculosis mycobacterium avium complex culture is negative [83].

Also of note, the CFF does not recommend the chronic usage of prophylactic anti-staphylococcal antibiotics, and does not have sufficient evidence to recommend the chronic usage of other inhaled or oral antibiotics (as listed in the Medscape review) in patients with *pseudomonas aeruginosa* infection [79].

As to the question of whether a combination of antibiotics would be more beneficial, in a 2015 Cochrane Review [84], Hurley attempted to find evidence to support the use of multiple IV antibiotics in order to provide a more efficacious treatment for patients with CF suffering from pulmonary exacerbations. Hurley retrospectively analyzed 1717 CF patients, and found low quality evidence that patients who received

two IV antibiotics experienced a greater improvement in lung function than in patients who received only one IV antibiotic [84]. However, when he limited patient data to placebo controlled studies, no evidence was found to suggest that using two intravenous antibiotics is more effective in improving lung function than one intravenous antibiotic [84]. Further, there was no evidence showing that one route of administration (inhaled, intravenous, or oral) was better than another at treating pulmonary exacerbations [84]. Continuing research is needed to determine the most efficacious route of administration and antibiotic combinations. However, it should be noted that it is difficult to fully control a clinical trial due to ethics of giving a patient with CF a placebo over an antibiotic that is currently a front line therapy.

*Bronchodilators and Corticosteroids:*

Bronchodilators can be either short acting or long acting beta-2 agonists with or without an added corticosteroid [80]. Bronchodilators are administered via aerosol, nebulization, or a dry powder inhaler to CF patients [80]. In a 1999 study by Konstan published in *Pediatric Pulmonology*, it was found that 82% of sampled CF patients used inhaled bronchodilator therapy [85]. However, the data supporting the use is limited. According to Brand in a 2000 study published in the *Journal of the Royal Society of Medicine*, studies show that 50-60% of CF patients have an improved FEV1 after inhaling a bronchodilator, 30 percent show no change in FEV1, and 10-20% of patients have a lower FEV1 after use of an inhaled bronchodilator therapy [86]. Brand concluded that there is little evidence to support long-term usage of bronchodilators in patients with stable symptoms [86]. This raises the question of whether inhaled bronchodilator therapy

is efficacious in treating a patient with atypical CF, who is experiencing moderate, but stable symptoms. The CFF, in their 2013 review, concluded that there is insufficient evidence for or against the chronic use of beta-2 receptor agonists to decrease exacerbations and increase quality of life [79]. They note however, that short-term administration can benefit those with airway hyper responsiveness and prevent bronchospasm associated with the use of inhaled therapies [79]. The CFF also recommends against the chronic use of both inhaled and oral corticosteroids in patients without asthma or allergic bronchopulmonary aspergillosis [79]. However, approximately 50% of CF patients have some form of asthma, and a bronchodilator and corticosteroid therapy will improve their symptoms [87]. It is also recommended that a bronchodilator be used prior to chest physical therapy or use of a flutter valve [80, 87].

#### *Chest Physical Therapy:*

Chest physical therapy involves percussion of the chest wall by a caretaker, and the patient coughing in order to move mucus into the larger airways in the lung. More recently, the flutter valve was introduced. A 1999 study by Gondor showed that patients using the flutter valve showed an increased forced vital capacity and FEV1 over chest physical therapy alone [88].

#### *Hypertonic Saline:*

A 2012 review article by Reeves [77] published in the Scientific World Journal concluded that hypertonic saline solution is associated with an improvement in both lung function and pulmonary exacerbations, and that a synergistic effect is observed when

used combined with mucolytic agents such as dornase alfa (described in the following section). Three mechanisms of action have been proposed for inhaled hypertonic solution therapy. The first is that the salt solution draws water to apical membrane surface of the lung; the second is that LL-37, an antimicrobial peptide is released from glycosaminoglycans via a disruption in the electrostatic interaction between the two molecules; and third, is that the hypertonic saline solution disrupts the interaction between interleukin 8 (IL-8) and glycosaminoglycans allowing IL-8 to be degraded by proteolysis, thereby decreasing inflammation [77]. In their 2013 report, the CFF recommends the chronic usage of inhaled hypertonic saline to improve quality of life and decrease pulmonary exacerbations in all CF patients [79].

*Mucolytic Agents:*

Mucolytic agents such as dornase alfa (pulmozyme) are used to reduce the viscosity and surface tension in the sputum of the lung [89]. Functioning as a recombinant human DNase, dornase alpha cleaves extracellular DNA in the sputum and improves the clearance of mucus secretions [80]. In their 2013 report, the CFF strongly recommends the use of dornase alpha in patients with moderate to severe disease and also recommends the use of dornase alpha in patients with mild disease [79]. The CFF found that patients with moderate to severe disease, and mild disease to have a substantial and moderate effect, respectively [79].

*Orally administered NSAIDS:*

A 2007 Cochrane Review [90] concluded that a high dose of ibuprofen could decrease the rate of progression of CF lung disease - especially in children. Subsequently, since the 2007 CFF pulmonary treatments review, ibuprofen has been recommended to prevent the loss of lung function in patients with an FEV1 value that is greater than 60% of predicted [79]. However, it is still unknown whether chronic use of ibuprofen will benefit adults, and more research is needed to reach a conclusion [79].

**2) Traditional Therapies to Treat GI Based Atypical CF Symptoms:**

To treat pancreatic insufficiency or improve absorption during pancreatitis, pancrelipase, an enteric-coated pancreatic enzyme replacement therapy containing amylase, protease and lipase is administered [80]. Pancrelipase aids in protein, starch and fat digestion [80]. Since patients suffering from CF can suffer from fat-soluble vitamin deficiency, ADEK preparations containing vitamins A, D, E and K are supplemented due to malabsorption [80].



**Table 5: Pulmonary Treatments from the CFF. Adapted from [79]**

| Treatment  | Recommendation  |
|--|---|
| Inhaled tobramycin—moderate to severe disease*                   | For individuals with CF, 6 years of age and older, with moderate to severe lung disease and <i>Pseudomonas aeruginosa</i> persistently present in cultures of the airways, the CF Foundation strongly recommends the chronic use of inhaled tobramycin to improve lung function and quality of life, and reduce exacerbations.  |
| Inhaled tobramycin—mild disease*                                 | For individuals with CF, 6 years of age and older, with mild lung disease and <i>P. aeruginosa</i> persistently present in cultures of the airways, the CF Foundation recommends the chronic use of inhaled tobramycin to reduce exacerbations.   |
| Dornase alfa—moderate to severe disease*                         | For individuals with CF, 6 years of age and older, with moderate to severe lung disease, the CF Foundation strongly recommends the chronic use of dornase alfa to improve lung function, improve the quality of life, and reduce exacerbations.   |
| Dornase alfa—mild disease*                                       | For individuals with CF, 6 years of age and older, with asymptomatic or mild lung disease, the CF Foundation recommends the chronic use of dornase alfa to improve lung function and reduce exacerbations.  |
| Inhaled hypertonic saline  | For individuals with CF, 6 years of age and older, the CF Foundation recommends the chronic use of inhaled hypertonic saline to improve lung function and quality of life and reduce exacerbations.   |
| Azithromycin with <i>P. aeruginosa</i>                           | For individuals with CF, 6 years of age and older, with <i>P. aeruginosa</i> persistently present in cultures of the airways, the CF Foundation recommends the chronic use of azithromycin to improve lung function and reduce exacerbations.   |
| Oral antistaphylococcal antibiotics, prophylactic use            | For individuals with CF, the CF Foundation recommends against the prophylactic use of oral antistaphylococcal antibiotics to improve lung function and quality of life or reduce exacerbations.   |
| Inhaled corticosteroids  | For individuals with CF, 6 years of age and older, without asthma or allergic bronchopulmonary aspergillosis, the CF Foundation recommends against the routine use of inhaled corticosteroids to improve lung function or quality of life and reduce pulmonary exacerbations.   |
| Oral corticosteroids   | For individuals with CF, 6 years of age and older, without asthma or allergic bronchopulmonary aspergillosis, the CF Foundation recommends against the chronic use of oral corticosteroids to improve lung function, quality of life or reduce exacerbations.   |
| Other inhaled antibiotics  | For individuals with CF, 6 years of age and older, with <i>P. aeruginosa</i> persistently present in cultures of the airways, the CF Foundation concludes that the evidence is insufficient to recommend for or against the chronic use of other inhaled antibiotics (i.e., carbenicillin, ceftazidime, colistin, gentamicin) to improve lung function and quality of life or reduce exacerbations. |
| Oral antipseudomonal antibiotics                                 | For individuals with CF, 6 years of age and older, with <i>P. aeruginosa</i> persistently present in cultures of the airways, the CF Foundation concludes that the evidence is insufficient to recommend for or against the routine use of chronic oral antipseudomonal antibiotics to improve lung function and quality of life or reduce exacerbations.   |
| Leukotriene modifiers  | For individuals with CF, 6 years of age and older, the CF Foundation concludes that the evidence is insufficient to recommend for or against the routine chronic use of leukotriene modifiers to improve lung function and quality of life or reduce exacerbations.   |
| Inhaled or oral <i>N</i> -acetylcysteine, or inhaled glutathione | For individuals with CF, 6 years of age and older, the CF Foundation concludes that the evidence is insufficient to recommend for or against the chronic use of inhaled or oral <i>N</i> -acetylcysteine or inhaled glutathione to improve lung function and quality of life or reduce exacerbations.   |
| Inhaled anticholinergics   | For individuals with CF, 6 years of age and older, the CF Foundation concludes that the evidence is insufficient to recommend for or against the chronic use of inhaled anticholinergic bronchodilators to improve lung function and quality of life or reduce exacerbations.   |

**Table 5: Continued- Taken from [79]**

| Treatment  | Recommendation   |
|--|--|
| Ivacaftor*   | For individuals with CF, 6 years of age and older, with at least one G551D <i>CFTR</i> mutation, the Pulmonary Clinical Practice Guidelines Committee strongly recommends the chronic use of ivacaftor to improve lung function and quality of life and reduce exacerbations.  |
| Inhaled aztreonam—moderate to severe disease†                | For individuals with CF, 6 years of age and older, with moderate to severe lung disease and <i>Pseudomonas aeruginosa</i> persistently present in cultures of the airways, the CF Foundation strongly recommends the chronic use of inhaled aztreonam to improve lung function and quality of life.  |
| Inhaled aztreonam—mild disease†                              | For individuals with CF, 6 years of age and older, with mild lung disease and <i>P. aeruginosa</i> persistently present in cultures of the airways, the CF Foundation recommends the chronic use of inhaled aztreonam to improve lung function and quality of life.  |
| Chronic use of ibuprofen (age < 18 yr)                       | For individuals with CF, between 6 and 17 years of age, with an FEV <sub>1</sub> ≥ 60% predicted, the CF Foundation recommends the chronic use of oral ibuprofen, at a peak plasma concentration of 50–100 µg/ml, to slow the loss of lung function.   |
| Chronic use of ibuprofen (age ≥ 18 yr)                       | For individuals with CF, 18 years of age and older, the CF Foundation concludes that the evidence is insufficient to recommend for or against the chronic use of oral ibuprofen to slow the loss of lung function or reduce exacerbations.   |
| Azithromycin without <i>P. aeruginosa</i>                    | For individuals with CF, 6 years of age and older, without <i>P. aeruginosa</i> persistently present in cultures of the airways, the CF Foundation recommends the chronic use of azithromycin should be considered to reduce exacerbations.  |
| Chronic inhaled β <sub>2</sub> -adrenergic receptor agonists | For individuals with CF, 6 years of age and older, the CF Foundation concludes that the evidence is insufficient to recommend for or against chronic use of inhaled β <sub>2</sub> -adrenergic receptor agonists to improve lung function and quality of life or reduce exacerbations.   |
| Oral antistaphylococcal antibiotics, chronic use             | For individuals with CF, 6 years of age and older, with <i>Staphylococcus aureus</i> persistently present in cultures of the airways, the CF Foundation concludes that the evidence is insufficient to recommend for or against the chronic use of oral antistaphylococcal antibiotics to improve lung function and quality of life or reduce exacerbations. |

### **3) Current and Future Targeted Therapies:**

Since the discovery that cystic fibrosis was the result of a genetic mutation in the CFTR gene in 1989, the race has been on to develop small molecule based therapies that target the underlying cause of the disease. Because there are six general classes of mutations with varying effects on the total amount of functional CFTR channel translated or present at the apical surface in CF, drugs that treat the disease must be specific to the mutation. In general, a drug must be either a CFTR potentiator, or a corrector. A drug that is a CFTR potentiator increases ion flow through the CFTR channel that is already present at the apical membrane, and a CFTR corrector is a compound that increases the delivery of CFTR protein to the apical membrane [17].

The first approved drug that treats the underlying cause of CF at the molecular level is Ivacaftor, a CFTR potentiator for patients with at least one copy of the G551D mutation [91]. The G551D mutation is a class III CFTR mutation, of which 5% of CF patients carry. In patients with the G551D mutation, CFTR protein is processed and delivered to the apical membrane, but there is a block in channel gating, and the channel does not permit chloride ion to flow through [58].

Clinical studies of ivacaftor showed the following: In a 2013 double blinded, randomized, placebo control trial by Davies, Ivacaftor was found to increase FEV1 by 12.5 percentage points, and significantly decrease sweat chloride levels to the intermediate range [91]. Mckone, also in 2013, showed that ivacaftor decreases the rate of decline in FEV1, and that ivacaftor was generally well tolerated, with only 1% of children and adults taking the drug having discontinued the trial due to adverse events

[92]. McKone also showed that over 144 weeks of taking ivacaftor, children and adults gained an average of 4.1kg and 14.8kg respectively [92]. Rowe, demonstrated that ivacaftor caused a significant decline in *pseudomonas aeruginosa* infection, decreased sweat chloride to an average of 53.8mmol/L, improved BMI, and increased the rate of weight gain compared to placebo [93]. Another study showed that ivacaftor improved FEV1 in patients with a R117H mutation [17]. Thus, if a patient presenting with atypical CF has a single copy of the G551D mutation, or a single copy of the R117H mutation, ivacaftor is likely to improve their clinical outlook.

Overall, clinical studies showed that ivacaftor was a breakthrough for patients with a G551D mutation. It also gave researchers a proof of concept: restoring CFTR channel function causes a large improvement in symptoms for individuals with the G551D mutation, independent of genetic modifiers or environmental factors that are known to influence disease severity. However, this breakthrough left more than 90% of CF patients without any new hope. According to Boyle's 2014 CFF presentation, 87% of patients have 1 copy of the F508del, of which 46.5% are homozygous, and 39% are heterozygous [17]. For them, ivacaftor was not expected to have an effect. Flume, in a trial published in an article in *Chest*, confirmed that ivacaftor has no effect on patients who are homozygous for the F508del mutation [94]. The F508 mutation is a class II mutation resulting in aberrant processing of the protein. For these patients, a CFTR corrector would be needed, which was in the pipeline. The compound was lumacaftor. Lumacaftor is a drug that was shown to correct F508del misprocessing and increase the amount of CFTR protein that is located at the apical cell surface [95].

The combination of lumacaftor and ivacaftor (Orkambi) was approved by the FDA in July 2015 for patients who are homozygous for the F508del mutation and older than twelve years old. Wainright showed in two phase III, randomized, double blind, placebo controlled trials for Orkambi that FEV1 improved 4.3 to 6.7%, pulmonary exacerbations declined 30-39%, and that there was a lower rate of hospitalization for patients in the study [95]. This was another breakthrough, the difference being that this time the majority of patients suffering from CF served to benefit. However, Orkambi does not reduce sweat chloride or improve FEV1 in patients who are heterozygotes for the F508del mutation. Thus, this drug is likely to have no impact on patients with atypical CF [80]. Despite the clinical success of Orkambi, there is a controversy over the cost of the medication, which retails for almost \$260,000 per year - although Orkambi is cheaper than ivacaftor, which costs \$310,000 per year [96]. It is likely that these drugs will strain the Medicare, Medicaid, and private health insurance system in the United States, causing a net increase in health care costs to the system, and that some patients may not be able to get the drug due to the exorbitant cost. Government or private insurance control over who gets these targeted medications may be a limiting factor in CF patient survival in the future.

However, for atypical CF patients, another compound, VX-661, which works like lumacaftor is in the pipeline. A phase II randomized, double blind, placebo controlled study of VX-661 in combination with ivacaftor in 2012 showed a 9% increase in FEV1 over ivacaftor alone [97]. VX-661 is still under investigation, so for now, F508del heterozygotes, of which many patients with atypical CF are, will have to wait. The cost of

the VX-661 is likely to be near the cost of Orkambi, and whether or not an atypical CF patient's insurer will cover the drug will be a determinant in the clinical outcome for atypical CF patients.

Other therapies in the pipeline involve gene therapy and anti-inflammatory drug development. Shire Pharmaceuticals is working on an aerosol based therapy containing normal CFTR mRNA designed to deliver wild type mRNA to the lung, where it could be translated into proper folded protein [98]. Also, sildenafil, a phosphodiesterase inhibitor is being tested for anti-inflammatory properties in patients with CF [98].

## **PART 5: CONCLUSIONS**

Atypical cystic fibrosis, also referred to in the literature as non-classical CF, adult onset CF, adult diagnosed CF, or CFTR related disease is a less severe form of CF in which patients have mild mutations in the CFTR gene. Mutations often involve one severe class I, II, or III mutation on one chromosome in combination with a mild class IV or V mutation on the second chromosome, allowing for residual function of the CFTR channel, and preventing the classical presentation of cystic fibrosis from occurring. Perhaps, as some have already suggested, the best name for atypical CF is residual function CF, as this characterizes the underlying problem of the disease most precisely. Acute respiratory symptoms are the most prominent symptoms at the time of diagnosis, although sinus disease, idiopathic pancreatitis, a familial history of CF and male infertility are also signs. Diagnosis of atypical CF is difficult and expensive, requiring specialty physicians and genetic testing. Increasing physician awareness of the adult population with CF is a paramount in improving the diagnosis, care and treatment of patients with atypical CF. Now that newborn screening for CF occurs in all 50 states of the United States, the diagnosis of atypical CF may be rare after the next 20 years. However, we are still learning about new, mild mutations, and it is difficult and expensive to test a newborn for every possible mutation. Therefore, some people may not be diagnosed until adulthood despite newborn screening. Diagnosis of atypical CF is important, as pulmonary symptoms can still be severe. Patients with atypical CF likely stand to benefit the most from the recent advances in molecular therapy for classical CF, but we cannot treat a patient with these new drugs without a diagnosis. A small increase

in functional CFTR in patients with atypical CF, who already have CFTR with residual function, should have a profound clinical impact. However, until a compound that is effective for patients heterozygous for the F508 mutation is approved for use, many patients with atypical CF are still relegated to the use traditional therapies that treat the symptoms of the disease, rather than the underlying cause. Once a drug is approved, a cost benefit analysis will have to be performed by patients, physicians, and the health care system, as the cost of the drug will likely be over \$200,000 per year if Ivacaftor and Orkambi are any indication. Further research, perhaps a prospective study following adult males diagnosed with CBAVD and two CFTR mutations would provide insight into the temporal relationship between CFTR mutations and the development of symptoms of atypical CF. One study mentioned earlier also noted that a higher proportion of females than males diagnosed with CF as an adult. Further research should be aimed at determining if atypical CF is more prominent in either sex. A comprehensive document providing information on the management of atypical CF has yet to be made.. Studies evaluating the efficacy of treatment in mild disease are few and far between, making it difficult for physicians to come to a conclusion on the best course of treatment for atypical, or mild CF cases. Further, once a molecular therapy for treating F508del heterozygotes exists, research will need to determine how much residual damage has been accrued in the lung in patients with atypical CF, and what therapies will need to be included in a therapeutic regimen in addition to molecular based therapy in order to provide the largest benefit to the patient.



## REFERENCES

1. O'Sullivan, B. P., & Freedman, S. D. Cystic fibrosis. *The Lancet* 2009; 373(9678), 1891–1904.
2. Kartner N, et al. Expression of the cystic fibrosis gene in non-epithelial invertebrate cells produces a regulated anion conductance. *Cell* 1991; 64:681–691.
3. Voter KZ, Ren CL. Diagnosis of cystic fibrosis. *Clinical Reviews In Allergy and Immunology* 2008; 35(3):100-6.
4. Schram, C. A. Atypical cystic fibrosis. *Canadian Family Physician* 2012; 58(12), 1341–1345.
5. Cutting, G. R. Cystic fibrosis genetics: from molecular understanding to clinical application. *Nature Reviews Genetics* 2015; 16(1), 45–56.
6. Kerem E. Atypical CF and CF related diseases. *Paediatric Respiratory Reviews* 2006; 7(Suppl 1):S144-6.
7. Boyle, MP. Is it Cystic Fibrosis? Identifying a patient with atypical CF. *Medscape Education Pulmonary Medicine*. 2014.
8. Van Biezen P, Overbeek SE, Hilvering C. Cystic fibrosis in a 70 year old woman. *Thorax* 1992; 47(3):202-3.
9. Patient Registry: Annual Data Report 2012: Cystic Fibrosis Foundation; 2012. Available at: <http://www.cff.org/UploadedFiles/research/ClinicalResearch/PatientRegistryReport/2012-CFF-Patient-Registry.pdf>.
10. American Lung Association. Cystic fibrosis (CF). State of Lung Disease in Diverse Communities 2010: American Lung Association; 2010:41–44. Available at: [http://www.lung.org/assets/documents/publications/lung-diseasedata/solddc\\_2010.pdf](http://www.lung.org/assets/documents/publications/lung-diseasedata/solddc_2010.pdf).
11. Nick JA, Chacon CS, et al. Effects of gender and age at diagnosis on disease progression in long-term survivors of cystic fibrosis. *American Journal of Respiratory and Critical Care Medicine* 2010; 182:614-626.
12. Gibson L, Cooke. Test For Concentration Of Electrolytes In Sweat In Cystic Fibrosis Of The Pancreas Utilizing Pilocarpine By Iontophoresis. *Pediatrics* 1959; 23:545.
13. Knowlton, R. G., Cohen-Haguenauer, O., et al. A polymorphic DNA marker linked to cystic fibrosis is located on chromosome 7. *Nature* 1985, 318(6044), 380–382.

14. Rommens, J. M., et al. Identification of the cystic fibrosis gene: chromosome walking and jumping. *Science* 1989; 245(22), 1059–1065.
15. Riordan, J. R., et al. Identification of the cystic fibrosis gene: cloning and characterization of complementary DNA. *Science* 1989; 245 (4922), 1066–1073.
16. CFTR2: CFTR2: Clinical and Functional Translation of CFTR. Available at: <http://www.cftr2.org/faq.php> Accessed Feb 2016.
17. Boyle, M. Scaling the Mountain: The Journey to Delivering Transformational CF Therapeutics. 2014 CF Foundation National Conference. Available online at [https://www.nacconference.org/art/plenaryarchives/2014\\_Boyle.pdf](https://www.nacconference.org/art/plenaryarchives/2014_Boyle.pdf)
18. Paranjape SM, Zeitlin PL. Atypical cystic fibrosis and CFTR-related diseases. *Clinical Reviews in Allergy and Immunology* 2008; 35 (3):116-23.
19. Cystic Fibrosis Foundation. Cystic Fibrosis Foundation Patient Registry Annual Data Report 2012. Cystic Fibrosis Foundation; 2012. <https://www.cff.org/About-Us/Assets/2012-Annual-Report/>.
20. Coates EO Jr. Characteristics of cystic fibrosis in adults: a report of seven patients. *Diseases of the Chest* 1966; 49 (2):195-204.
21. Davé S, Honney S, Raymond J, Flume PA. An unusual presentation of cystic fibrosis in an adult. *American Journal of Kidney Diseases* 2005; 45 (3):e41-4.
22. Gan KH, et al. Genetic and clinical features of patients with cystic fibrosis diagnosed after the age of 16. *Thorax* 1995; 50 (12):1301-4.
23. Ziedalski TM, Kao PN, Henig NR, Jacobs SS, Ruoss SJ. Prospective analysis of cystic fibrosis transmembrane regulator mutations in adults with bronchiectasis or pulmonary nontuberculous mycobacterial infection. *Chest* 2006; 130 (4):995-1002.
24. Griesenbach, U., & Alton, E. W. F. W. Recent advances in understanding and managing cystic fibrosis transmembrane conductance regulator dysfunction. *F1000Prime Reports* 2015.
25. Jain M, Goss CH. Update in cystic fibrosis 2013. *American Journal of Respiratory and Critical Care Medicine* 2014; 189: 1181–6.
26. Gilljam M, Björck E. Cystic fibrosis diagnosed in an elderly man. *Respiration* 2004; 71(1): 98-100.

27. Alghisi, F., et al. Diagnosis of atypical CF: A case-report to reflect. *Journal of Cystic Fibrosis* 2008, 7(4), 292–294.
28. Steinraths M, et al. Delays in diagnosing cystic fibrosis. Can we find ways to diagnose it earlier? *Canadian Family Physician* 2008; 54:877-83.
29. The Leeds Method of Management. 2008. Cystic fibrosis and the basic problem Leeds Regional Adult and Paediatric Cystic Fibrosis Units, St James's University Hospital, Leeds, UK. Available from <http://www.cysticfibrosismedicine.com>
30. CFTR Mutation Data Base. The CFTR Domain. April 2011. <http://www.genet.sickkids.on.ca/CftrDomainPage.html>
31. Toth, LJ. GMS AN722: Cellular Organization of Tissues Syllabus. Fall 2014. Boston University School of Medicine.
32. König, J., et al. The cystic fibrosis transmembrane conductance regulator (CFTR) inhibits ENaC through an increase in the intracellular Cl<sup>-</sup> concentration. *European Molecular Biology Association Reports* 2001; 2(11), 1047–1051.
33. Di, A., Brown, et al. CFTR regulates phagosome acidification in macrophages and alters bactericidal activity. *Nature Cell Biology* 2006, 8(9), 933–944.
34. Schwiebert, E. M., et al. CFTR regulates outwardly rectifying chloride channels through an autocrine mechanism involving ATP. *Cell* 1995; 81(7), 1063–1073.
35. CFTR drives Na<sup>+</sup>- cotransport in pancreatic duct cells: a basis for defective secretion in CF | *Cell Physiology*. Retrieved February 22, 2016, from <http://ajpcell.physiology.org/content/276/1/C16>
36. Garcia-Diaz, F. Human Physiology A: Cell Physiology, Blood, Cardiovascular and Gastrointestinal Systems. Lab Discussion #10. Fall 2014.
37. Rosenstein BJ, Cutting GR. The diagnosis of cystic fibrosis: a consensus statement. Cystic Fibrosis Foundation Consensus Panel. *Journal of Pediatrics* 1998; 132: 589–595.
38. Boyle, M. P., & De Boeck, K. A new era in the treatment of cystic fibrosis: correction of the underlying CFTR defect. *The Lancet Respiratory Medicine* 2013; 1(2), 158–163.
39. Lazrak, A., et al. The silent codon change I507-ATC->ATT contributes to the severity of the ΔF508 CFTR channel dysfunction. *FASEB Journal: Official Publication of the Federation of American Societies for Experimental Biology* 2013; 27(11), 4630–4645.

40. The Leeds Method of Management. 2008. The genetics of Cystic Fibrosis. Leeds Regional Adult and Paediatric Cystic Fibrosis Units, St James's University Hospital, Leeds, UK. Available from <http://www.cysticfibrosismedicine.com>
41. Rodman DM, et al. Late diagnosis defines a unique population of long-term survivors of cystic fibrosis. *American Journal of Respiratory and Critical Care Medicine* 2005; 171:621-626.
42. Noone PG, Knowles MR. 'CFTR-opathies': disease phenotypes associated with cystic fibrosis transmembrane regulator gene mutations. *Respiratory Research* 2001; 2:328-332.
43. Kerem E, et al. The relation between genotype and phenotype in cystic fibrosis--analysis of the most common mutation (F508). *New England Journal of Medicine*. 1990; 323:1517-1522.
44. Wallis, C. Atypical cystic fibrosis--diagnostic and management dilemmas. *Journal of the Royal Society of Medicine* 2003; 96 Suppl 43, 2-10.
45. The Cystic Fibrosis Genotype-Phenotype Consortium. Correlation between genotype and phenotype in patients with cystic fibrosis. *New England Journal of Medicine*. 1993; 329:1308-1313.
46. Wilschanski M, et al. Correlation of sweat chloride concentration with classes of the cystic fibrosis transmembrane conductance regulator gene mutations. *Journal of Pediatrics*. 1995; 127:705-710.
47. McKone EF, Goss CH, Aitken ML. CFTR genotype as a predictor of prognosis in cystic fibrosis. *Chest*. 2006; 130:1441-1447.
48. Mekus F, et al. Categories of F508 homozygous cystic fibrosis twin and sibling pairs with distinct phenotypic characteristics. *International Society for Twin Studies*. 2000; 3:277-293.
49. Collaco JM, et al. Quantification of the relative contribution of environmental and genetic factors to variation in cystic fibrosis lung function. *Journal of Pediatrics*. 2010; 157:802-807.
50. Acton JD, Wilmott RW. Phenotype of CF and the effects of possible modifier genes. *Paediatric Respiratory Review*. 2001; 2:332-9.
51. Arkwright, P. D., et al. TGF-beta(1) genotype and accelerated decline in lung function of patients with cystic fibrosis. *Thorax* 2000, 55(6), 459-462.

52. Garred P, Pressler T, Madsen HO, et al. Association of mannose- binding lectin gene heterogeneity with severity of lung disease and survival in cystic fibrosis. *The Journal of Clinical Investigation* 1999; 104:431–7.
53. Taylor ME, et al. Structure and evolutionary origin of the gene encoding a human serum mannose- binding protein. *Biochemical Journal* 1989; 262:763–71.
54. Green DM, et al. Heritability of respiratory infection with *Pseudomonas aeruginosa* in cystic fibrosis. *Journal of Pediatrics*. 2012; 161:290–295.
- 55 Zielenski J, et al. Detection of a cystic fibrosis modifier locus for meconium ileus on human chromosome 19q13. *Nature Genetics* 1999; 22:128–9.
56. De Boeck K, et al. Cystic fibrosis: terminology and diagnostic algorithms. *Thorax* 2006; 61(7):627-35.
57. Nakamura, C. T., et al. Correlation between digital clubbing and pulmonary function in cystic fibrosis. *Pediatric Pulmonology* 2002; 33(5), 332–338.
58. Pettit, R. S., & Fellner, C. CFTR Modulators for the Treatment of Cystic Fibrosis. *P & T: A Peer-Reviewed Journal for Formulary Management* 2014, 39(7), 500–511.
59. Quinzii C, Castellani C. The cystic fibrosis transmembrane regulator gene and male infertility. *Journal of Endocrinological Investigation* 2000; 23(10):684-9.
60. De Rose AF, et al. Congenital bilateral absence of the vasa deferentia and related respiratory disease. *Società italiana di ecografia urologica e nefrologica Associazione ricerche in urologia* 2003;75(4):214-6.
61. Oppenheimer EA, et al. Cervical mucus in cystic fibrosis: a possible cause of infertility. *American Journal of Obstetrics and Gynecology* 1970;108(4):673-4.
62. Schoyer KD, et al. Infertility and abnormal cervical mucus in two sisters who are compound heterozygotes for the cystic fibrosis (CF) DeltaF508 and R117H/7T mutations. *Fertility and Sterility* 2008; 90(4):1201.e19-22.
63. Starkman H, Das S. Cystic fibrosis presenting as new onset diabetes mellitus in adolescent twins. *Pediatric Diabetes* 2004; 5(2):99-101.
64. Keating CL, et al. Classic respiratory disease but atypical diagnostic testing distinguishes adult presentation of cystic fibrosis. *Chest*. 2010; 137:1157-1163.
65. Gilljam M, et al. Clinical manifestations of cystic fibrosis among patients with diagnosis in adulthood. *Chest* 2004; 126(4):1215-24.

66. Hubert D, et al. Diagnosis of cystic fibrosis in adults with diffuse bronchiectasis. *Journal of Cystic Fibrosis* 2004; 3(1):15-22.
67. Coste A, et al. Atypical sinusitis in adults must lead to looking for cystic fibrosis and primary ciliary dyskinesia. *Laryngoscope* 2004; 114(5):837-43.
68. Akl ME, Mallory G. A 16-year-old girl with cough and abdominal pain. *Annals of Allergy, Asthma and Immunology* 1995; 75(1):15-8.
69. Choudari CP, et al. Pancreatitis and cystic fibrosis gene mutations. *Gastroenterology Clinics of North America* 1999; 28:543-9.
70. Sharer N, et al. Mutations of the cystic fibrosis gene in patients with chronic pancreatitis. *New England Journal of Medicine* 1998; 339:645-52.
71. Chu CS, et al. Genetic basis of variable exon 9 skipping in cystic fibrosis transmembrane conductance regulator mRNA. *Nature Genetics* 1993;3:151-6.
72. Bombieri C, et al. Recommendations for the classification of diseases as CFTR-related disorders. *Journal of Cystic Fibrosis*. 2011;10:S86-S102
73. Jarvi K, et al. Cystic fibrosis transmembrane conductance regulator and obstructive azospermia. *Lancet* 1995; 345: 1578.
74. Farrell PM, et al. Guidelines for diagnosis of cystic fibrosis in newborns through older adults: Cystic Fibrosis Foundation consensus report. *Journal of Pediatrics* 2008; 153(2):S4-14.
75. Hall SK, et al. Sweat sodium and chloride concentrations -- essential criteria for the diagnosis of cystic fibrosis in adults. *The Annals of Clinical Biochemistry* 1990; 27(Pt 4):318-20.
76. Wilschanski M, et al. Nasal potential difference measurements in patients with atypical cystic fibrosis. *European respiratory journal* 2001; 17(6):1208-15.
77. Reeves, E. P., et al. Hypertonic Saline in Treatment of Pulmonary Disease in Cystic Fibrosis. *The Scientific World Journal* 2012, 1-11.
78. "International Guidelines for the Selection of Lung Transplant Candidates", *American Journal of Respiratory and Critical Care Medicine*, Vol. 158, No. 1 (1998), pp. 335-339.
79. Mogayzel, P. J., et al, the Pulmonary Clinical Practice Guidelines Committee. (2013). Cystic Fibrosis Pulmonary Guidelines: Chronic Medications for Maintenance of Lung Health. *American Journal of Respiratory and Critical Care Medicine*, 187(7), 680-689.

80. Sharma, G. Cystic Fibrosis Medication: Enzymes, Pancreatic, Vitamins, Bronchodilators, Mucolytic Agents, CFTR Potentiators, Antibiotics. (n.d.). Retrieved February 3, 2016, from <http://emedicine.medscape.com/article/1001602-medication#1>
81. Wainwright CE, Quittner AL, et al. Aztreonam for inhalation solution in patients with cystic fibrosis, mild lung impairment, and *P. aeruginosa*. *Journal of Cystic Fibrosis* 2011; 10:234–242.
82. Southern K, Barker P, Solis-Moya A, Patel L. Macrolide antibiotics for cystic fibrosis. *Cochrane Database of Systematic Reviews* 2004.
83. Griffith, D. E., Aksamit, T., et al. An Official ATS/IDSA Statement: Diagnosis, Treatment, and Prevention of Nontuberculous Mycobacterial Diseases. *American Journal of Respiratory and Critical Care Medicine* 2007, 175(4), 367–416.
84. Cochrane review Hurley, M. N., Prayle, A. P., & Flume, P. Intravenous antibiotics for pulmonary exacerbations in people with cystic fibrosis. In *The Cochrane Collaboration* (Ed.), *Cochrane Database of Systematic Reviews* 2015. Chichester, UK: John Wiley & Sons, Ltd.
85. Konstan MW, et al. Investigators and coordinators of the epidemiologic study of cystic fibrosis. Patterns of medical practice in cystic fibrosis: Part II. Use of therapies. *Pediatric Pulmonology* 1999; 28:248–54.
86. Brand, P. L. (2000). Bronchodilators in cystic fibrosis. *Journal of the Royal Society of Medicine*, 93 (Suppl 38), 37–39.
87. The Leeds Method of Management. April, 2008. Bronchodilators. Leeds Regional Adult and Paediatric Cystic Fibrosis Units, St James's University Hospital, Leeds, UK. Available from <http://www.cysticfibrosismedicine.com>
88. Gondor, M., et al. Comparison of Flutter device and chest physical therapy in the treatment of cystic fibrosis pulmonary exacerbation. *Pediatric Pulmonology* 1999, 28(4), 255–260.
89. Collier, J. Dornase-alfa and orphan drugs. *The Lancet* 1995, 346(8975), 633.
90. Lands LC, Stanojevic S. Oral non-steroidal anti-inflammatory drug therapy for cystic fibrosis. *Cochrane Database of Systematic Reviews* 2007; CD001505.
91. Davies: Davies, J. C., Wainwright, et al. VX08-770-103 (ENVISION) Study Group. . Efficacy and safety of ivacaftor in patients aged 6 to 11 years with cystic fibrosis with a G551D mutation. *American Journal of Respiratory and Critical Care Medicine* 2013, 187(11), 1219–1225.

92. McKone, E. F., Borowitz, D., et al. Long-term safety and efficacy of ivacaftor in patients with cystic fibrosis who have the Gly551Asp-CFTR mutation: a phase 3, open-label extension study (PERSIST). *The Lancet Respiratory Medicine* 2014, 2(11), 902–910.
93. Rowe-Rowe, S. M., Heltshe, S. L., et al, GOAL Investigators of the Cystic Fibrosis Foundation Therapeutics Development Network. Clinical mechanism of the cystic fibrosis transmembrane conductance regulator potentiator ivacaftor in G551D-mediated cystic fibrosis. *American Journal of Respiratory and Critical Care Medicine* 2014, 190(2), 175–184.
94. Flume PA, et al. Ivacaftor in subjects with cystic fibrosis who are homozygous for the F508del-CFTR mutation. *Chest* 2012; 142:718–724.
95. Wainwright, C. E., Elborn, J. S., et al. Lumacaftor–Ivacaftor in Patients with Cystic Fibrosis Homozygous for Phe508del CFTR. *New England Journal of Medicine* 2015, 373(3), 220–231.
96. Orkambi’s Slick Unveiling Puts Insurers in a Bind. Retrieved February 22, 2016, from <http://www.managedcaremag.com/archives/2015/8/orkambis-slick-unveiling-puts-insurers-bind>
97. National Institutes of Health. Study of VX-661 alone and in combination with VX-770 in subjects homozygous to the F508del-CFTR mutation (2012). Available at: <http://clinicaltrials.gov/ct2/show/NCT01531673>.
98. Barnes, Bridget. CFRI Newsletter. Spring 2015. Accessible at <http://www.cfri.org/pdf/2015.spring.newsletter.pdf>



## CURRICULUM VITAE

### **RYAN QUINN**

Born: July 1991

**415-328-8603**

[rkquinn@bu.edu](mailto:rkquinn@bu.edu)

Novato, CA

### **Education:**

*Graduate:* Boston University School of Medicine, 2014-2016

MS Medical Science degree candidate (expected May 2016)

*GPA:* 3.86

*Undergraduate:* University of California, Santa Barbara, 2009-2013

*Degree:* BS Pharmacology

### **Bench Based Research Experience:**

*Buck Institute for Research on Aging:* Intern in the Kennedy Lab

*Nov 2015- Current*

- \*Protein purification from rat liver, muscle, fat and heart samples
- \*Bradford/DC assays to measure protein concentration
- \*Western Blotting

*Anacor Pharmaceuticals:* Full time research intern

*September 2013 to March 2014*

- \*Identified a drug scaffold for treatment of a skin disease
- \*Developed protocol to obtain/purify a specific enzyme from human skin
- \*Protein expression and purification
- \*Developed biochemical assays
- \*ELISA
- \*Library plate screening (Single point and IC50 Analysis)
- \*Maintained stock of C. Elegans

### **Clinical Research Experience:**

*Clinical Research Assistant:* San Francisco General Hospital, Emergency Department

*Summers 2011-2012:*

- \*Identified, obtained consent and enrolled patients applicable to ongoing studies at the SFGH Emergency Room and entered data into the research records.
- \*Shadowed emergency medicine physicians/residents at a level 1 trauma center.

### **Other Work Experience**

*Mike's Bikes San Rafael, CA:* Bicycle Repair Technician

*November 2015-Current*

Northstar at Tahoe: Mountain Bike Instructor/Guide for the Bike Academy  
*May 2014- August 2014*

Rolling Hills Club: Lifeguard  
*Summer 2010-2011*

**Volunteer Work:**

Trips for Kids: San Rafael, CA

Ride leader assistant

Supervised wilderness bicycle trail rides for inner-city youth ages 8-17

**School Leadership and Extracurricular Activities:**

*Mountain Bike Captain for UCSB Cycling Team 2010-2012, Race Director 2012*

\*Organized team of 20+ riders. Managed travel to local races/nationals, directed recruitment efforts and ran UCSB Cowpie Classic Mountain Bike race, a race attended by about 150 individuals, for two years.

**Athletics:**

UCSB Mountain Bike Team:

\*Competed in Downhill, Dual Slalom, Super-D and XC in the Western Collegiate Cycling Conference all four years of college.

\*Qualified for the USA Cycling National Collegiate Mountain Biking Championships all four years

UCSB Water Polo Club Team: 2010-2011