

2012-04-05

# Effect of body composition methodology on heritability estimation of body fatness

---

Sonya J Elder, Susan B Roberts, Megan A McCrory, Sai Krupa Das, Paul J Fuss, Anastassios G Pittas, Andrew S Greenberg, Steven B Heymsfield, Bess Dawson-Hughes, Thomas J Bouchard, Edward Saltzman, Michael C Neale. 2012. "Effect of Body Composition Methodology on Heritability Estimation of Body Fatness.." Open Nutr J, Volume 6, pp. 48 - 58.

<https://hdl.handle.net/2144/28806>

*"Downloaded from OpenBU. Boston University's institutional repository."*



Published in final edited form as:

*Open Nutr J.* ; 6: 48–58. doi:10.2174/1874288201206010048.

## Effect of Body Composition Methodology on Heritability Estimation of Body Fatness

Sonya J. Elder<sup>1</sup>, Susan B. Roberts<sup>1,\*</sup>, Megan A. McCrory<sup>2</sup>, Sai Krupa Das<sup>1</sup>, Paul J. Fuss<sup>1</sup>, Anastassios G. Pittas<sup>3</sup>, Andrew S. Greenberg<sup>1</sup>, Steven B. Heymsfield<sup>4</sup>, Bess Dawson-Hughes<sup>1</sup>, Thomas J. Bouchard Jr<sup>5</sup>, Edward Saltzman<sup>1</sup>, and Michael C. Neale<sup>6</sup>

<sup>1</sup>Jean Mayer USDA Human Nutrition Research Center on Aging, Tufts University, 711 Washington St., Boston, MA 02111, USA

<sup>2</sup>Department of Foods and Nutrition, Purdue University, 700 W. State St., West Lafayette, IN 47907, USA

<sup>3</sup>Division of Endocrinology, Diabetes, and Metabolism, Tufts Medical Center, 800 Washington St, #268, Boston, MA 02111, USA

<sup>4</sup>Pennington Biomedical Research Institute, 6400 Perkins Rd., Baton Rouge, LA 70808-4124, USA

<sup>5</sup>Department of Psychology, University of Minnesota, Elliott Hall, 75 East River Rd., Minneapolis, MN 55455, USA

<sup>6</sup>Virginia Institute of Psychiatric and Behavioral Genetics and Department of Psychiatry, Virginia Commonwealth University, 800 Leigh St, Ste 1-110, Richmond, VA 23298, USA

### Abstract

Heritability estimates of human body fatness vary widely and the contribution of body composition methodology to this variability is unknown. The effect of body composition methodology on estimations of genetic and environmental contributions to body fatness variation was examined in 78 adult male and female monozygotic twin pairs reared apart or together. Body composition was assessed by six methods – body mass index (BMI), dual energy x-ray absorptiometry (DXA), underwater weighing (UWW), total body water (TBW), bioelectric impedance (BIA), and skinfold thickness. Body fatness was expressed as percent body fat, fat mass, and fat mass/height<sup>2</sup> to assess the effect of body fatness expression on heritability estimates. Model-fitting multivariate analyses were used to assess the genetic and environmental components of variance. Mean BMI was 24.5 kg/m<sup>2</sup> (range of 17.8–43.4 kg/m<sup>2</sup>). There was a significant effect of body composition methodology ( $p < 0.001$ ) on heritability estimates, with UWW giving the

© Elder et al.; Licensee Bentham Open

This is an open access article licensed under the terms of the Creative Commons Attribution Non-Commercial License (<http://creativecommons.org/licenses/by-nc/3.0/>) which permits unrestricted, non-commercial use, distribution and reproduction in any medium, provided the work is properly cited.

\*Address correspondence to this author at the Energy Metabolism Lab, USDA HNRCA at Tufts University, 711 Washington St, Boston, MA 02111, USA; Tel: (617) 556-3237; Fax: (617) 556-3122; [susan.roberts@tufts.edu](mailto:susan.roberts@tufts.edu).

### CONFLICT OF INTEREST

None declared.

highest estimate (69%) and BIA giving the lowest estimate (47%) for fat mass/height<sup>2</sup>. Expression of body fatness as percent body fat resulted in significantly higher heritability estimates (on average 10.3% higher) compared to expression as fat mass/height<sup>2</sup> ( $p=0.015$ ). DXA and TBW methods expressing body fatness as fat mass/height<sup>2</sup> gave the least biased heritability assessments, based on the small contribution of specific genetic factors to their genetic variance. A model combining DXA and TBW methods resulted in a relatively low FM/ht<sup>2</sup> heritability estimate of 60%, and significant contributions of common and unique environmental factors (22% and 18%, respectively). The body fatness heritability estimate of 60% indicates a smaller contribution of genetic variance to total variance than many previous studies using less powerful research designs have indicated. The results also highlight the importance of environmental factors and possibly genotype by environmental interactions in the etiology of weight gain and the obesity epidemic.

### Keywords

body composition; adiposity; twins; heritability; genetics

---

## INTRODUCTION

Body weights have risen dramatically worldwide over the past 25 years, and currently nearly 65% of U.S. adults and 30% of the world population are classified as overweight or obese [1, 2]. The etiology of obesity and overweight is clearly multifactorial [3], but the relative influence of genes versus the environment in affluent societies with high rates of obesity remains uncertain and may be changing.

As described elsewhere, the relative influence of genes is expressed as heritability [4,5]. This quantity is known as the broad heritability, which consists of all additive and non-additive effects of genetic factors, and is distinct from the additive genetic variance, often referred to as the narrow sense heritability. Previous studies have produced widely variable estimates for the (usually narrow sense) heritability of human adiposity, ranging from 50–90% for body mass index (BMI) [6], 55–83% for percent body fat [7–13], and 45–71% for fat mass [10, 14–18]. Most studies have used the twin study approach that compares monozygotic and dizygotic twins [4,7, 9, 11, 14–18], which may overestimate heritability [19], while others have used family and adoption study populations [8, 10, 12, 13] that may underestimate heritability [19]. Very few studies have involved monozygotic twins reared apart [19–24], which on theoretical grounds may provide the least biased estimates of heritability [19]. In addition to the influence of the study population type on estimates of heritability, another potential source of variability in heritability estimates of body fatness is the methodology used to measure and express body fatness. Several different approaches have been used in previous studies, including BMI, dual energy x-ray absorptiometry (DXA), and underwater weighing, but to our knowledge there has been no formal comparison of heritability estimates derived from these different measures of body composition. Furthermore, different approaches have been employed to express body fatness (for example, percent body fat and fat mass) without evaluation of the impact of different expressions on heritability estimates.

The objectives of this study were to assess the effects of six body composition methodologies and three body fatness expressions on the heritability of body fatness, and to identify the methods and expressions that introduce the least bias. This work was part of the Tufts Twin Study a cross-sectional investigation of the heritability of energy regulation measures in a population of monozygotic twins reared apart (MZAs) or reared together (MZTs) [4].

## MATERIALS AND METHODOLOGY

### Subjects

As described elsewhere [4] subjects were 157 adult men and women, aged 18–76 years who participated in the Tufts Twin Study at the Jean Mayer U.S. Department of Agriculture Human Nutrition Research Center on Aging (HNRCA) at Tufts University. They included 78 monozygotic twin pairs who were either reared apart since near birth (29 pairs) or together (49 pairs), and one singleton monozygotic twin whose reared-together twin did not participate in the study. The singleton twin was included in data analyses because singleton data may reduce biases due to non-random ascertainment [25]. Eligibility criteria included being healthy at the time of study and willing to travel to Boston to participate in the study. Individuals were ineligible if they suffered from disorders that are known to affect body composition, including diabetes, active cancer, heart disease, cachexia, eating disorders, and AIDS. Also excluded were pregnant women, amputees, and individuals who had required treatment for any psychiatric disorder or had gained or lost over 10 pounds in weight within the previous 12 months or over 5 pounds within the previous 6 months. MZAs were recruited through their participation in the Minnesota Study of Twins Reared Apart at the University of Minnesota [26] and lived in North America, Europe (United Kingdom, The Netherlands, Germany and Poland), South Africa, or Australia. MZTs were recruited by advertisements in the New England area. A few MZTs were from other parts of the United States, Canada, and Germany. Cultural differences between twin pairs were assumed to be minimal because all subjects lived in Western societies. The protocol was approved by the IRB at Tufts University and all subjects gave written and informed consent. We certify that all applicable institutional and governmental regulations concerning the ethical use of human volunteers were followed during this research.

### Protocol

Subjects came to the Metabolic Research Unit at the HNRCA for a study period of approximately four days and completed examinations and questionnaires relating to energy metabolism. Subjects from outside the United States spent a week in Minnesota before this study, which allowed for recovery from travel. Body fatness was assessed by six methods – BMI, DXA, underwater weighing, total body water, bioelectric impedance (BIA), and skinfold thickness – as described below. Typical coefficients of this variation for these measurements are 1%, 2%, 2%, 3–4%, and 5% respectively.

### Body Composition Methods

As described elsewhere [4], fasting body weight and height were measured and BMI determined.

Our usual procedures for DXA (model DPX-L, Lunar Radiation Corp, Madison, WI) were used to determine total body fat mass as described elsewhere [27]. Total body fat and fat-free mass (FFM) for the trunk and extremities were calculated as the mean of values determined by two whole body scans in each subject.

The underwater, or hydrostatic, weighing method – which is considered the classic body composition method because of its early development and widespread use [28] – was used to measure body density according to our standard protocol [29]. Residual lung volume was estimated using the Quanjer equation [30]. Hydrostatic measurements were repeated until at least three were within 1% body fat of each other, and then the average of three tests was used for analysis. Percent body fat was calculated from body density using the Siri equation [31]. Body density measurement can also be accomplished by air-displacement plethysmography, which gives essentially equivalent results to the underwater weighing method used in this study [32].

The isotope deuterium ( $^2\text{H}$ ) dilution technique was used to estimate percent body fat, as previously described [33]. Subjects consumed a 0.06 gram oral dose of deuterium-labeled water ( $^2\text{H}_2\text{O}$ ) per kilogram of body weight after an overnight fast and a collection of a baseline urine specimen. Urine specimens were collected at 3, 4, and 5 hours after dosing and abundances were measured by mass spectrometry. Total body water was calculated as the  $^2\text{H}_2\text{O}$  dilution space 5 hours after the dose, divided by 1.04 [34]. Fat free mass was calculated assuming a hydration of fat free mass of 0.732 [35]. Total body water fat mass values were excluded for three subjects. These subjects represent three MZA twin pairs who were extremely discordant for fat mass measured by total body water, but not discordant for fat mass measured by other methods. The twin whose total body water fat mass value was furthest from their mean fat mass by the other four methods was excluded from data analyses.

Bioelectrical impedance was measured from hand to foot using a BIA analyzer (RJL Systems, Detroit, MI). Resistance and reactance were measured in duplicate for each subject, and mean values were used to calculate FFM using the Lukaski *et. al.*, 1986 equation [36]. Fat mass and percent body fat were calculated from FFM and body weight.

Standard skinfold thickness measurement procedures were followed to obtain duplicate measurements at the following eight sites: tricep (left and right), bicep (left and right), subscapular (left and right), and suprailiac (left and right) [37]. Mean skinfold values were calculated for tricep, bicep, subscapular, and suprailiac regions. Body density was estimated with the Durnin and Womersley equations for a population of age 17–62 years [38], using all four skinfold measurements. Percent body fat was calculated by using the Siri equation [31]. Fat mass was calculated from body weight and percent body fat.

### Expression of Fat Mass Variables

Results were compared across three expressions of body fatness: fat mass as a percentage of body weight, fat mass (kg), and fat mass/height<sup>2</sup>(kg/m<sup>2</sup>). Consideration of the different metrics of body fatness led to the selection of fat mass/height<sup>2</sup> as the most appropriate. Ideally, a body fatness metric should be independent of other factors that may influence fat

mass, such as height. In fact, height and fat mass were not correlated in this study population ( $r$  ranged from 0.01 to 0.09, depending on body composition method,  $p = 0.28$ ). However, FFM was associated with height ( $r$  ranged from 0.72 to 0.82, depending on body composition method,  $p < 0.001$ ), and a power regression revealed that expression of body leanness as  $\text{FFM}/\text{height}^2$  appropriately adjusted for height (data not shown). Therefore, fat mass/ $\text{height}^2$  was identified as the most appropriate expression of body fatness in order to be consistent with  $\text{FFM}/\text{height}^2$  and BMI, and was used as the primary expression against which other expressions were compared. Percent body fat was also chosen for comparison because, although lean body mass is known to be heritable and therefore its heritability will bias heritability estimates of percent body fat, it is a commonly used way to express body fatness and was used previously in body fatness heritability studies. Fat mass in kilograms was additionally chosen for use because it is unrelated to height and has also been used in previous heritability studies.

### Statistical Analysis

Descriptive statistics were calculated using SAS 9.1 [39]. To obtain normal or near-normal distributions, some variables were transformed using a natural log transformation (BMI, percent body fat by underwater weighing and total body water, all fat mass variables, and all fat mass/ $\text{height}^2$  variables.) Log transformed variables were then multiplied by 100 to increase the variance, which facilitated variance decomposition. Intrapair (intrafamily) MZA and MZT correlation coefficients were calculated as described elsewhere using SPSS 15.0 [4,40]. Model-fitting analyses were based on the decomposition of variance into genetic (G), common or shared environmental (C), and unique or non-shared environmental (E) components. Genetic variance ( $V_G$ ) is caused by differences in genes between individuals. The distinction between genetic variance due to dominance versus additive effects cannot be evaluated in an MZA/MZT study because both types share 100% of their genetic material, and therefore all additive and non-additive genetic variance components. Common environmental variance ( $V_C$ ) is due to environmental factors responsible for resemblance between family members, while unique environmental variance ( $V_E$ ) is due to environmental factors that contribute to differences between family members [5]. Unique environmental variance comprises any variance that is not due to genetic or common environmental factors, including variance due to measurement error. Total phenotypic variance ( $V_P$ ) can be represented as  $V_P = V_G + V_C + V_E$  and variance decomposition depicted in Fig. (1). The covariance of MZAs ( $\text{COV}_{\text{MZA}}$ ) is  $V_G$  and the covariance of MZTs ( $\text{COV}_{\text{MZT}}$ ) is  $V_G + V_C$ .

The MZA/MZT twin model used here is based on the following assumptions: (1) traits follow polygenic autosomal inheritance; (2) the observed phenotypic variance is a linear additive function of genetic and environmental variances; (3) genetic and environmental effects are uncorrelated and there is no genotype by environmental interaction; (4) there is no selective placement (non-random adoption of twins into similar families); (5) genetic and environmental factors are of the same magnitude in males and females [42]. Note also that any genetic effects of assortative mating contribute to  $V_G$  and that differences in methylation within a twin pair contribute to  $V_E$ .

Model-fitting analyses were performed using Mx, a structural equation modeling software package [43]. Mx fits the MZA/MZT GCE model to the raw observed data. It estimates parameters using maximum likelihood, and computes goodness-of-fit statistics based on minus twice the natural logarithm of the likelihood ( $-2\ln L$ ). Likelihood ratio tests (LRT) are used to test hypotheses, because under certain regularity conditions, the difference in  $-2\ln L$  between nested models (which differ because one or more parameters are constrained to equal each other or specific values) is asymptotically distributed as  $\chi^2$  with degrees of freedom (df) equal to the difference in the number of free parameters in the two models. However, under the null hypothesis that a variance component is zero, the likelihood-ratio test is distributed as a 50:50 mixture of  $\chi^2$  with 1 degree of freedom, and zero [44, 45].

Multivariate analysis was used to determine the extent to which measures from different body composition methods share genetic and environmental influences, while taking into account any correlation between them. Analyses were performed in three variable groups (percent body fat and BMI, fat mass and BMI, fat mass/height<sup>2</sup> and BMI) in order to explore the effect of body fatness expression on heritability, each of which consisted of six variables (BMI, DXA, underwater weighing, total body water, BIA, and skinfold thickness). BMI was included in all of the models to investigate the extent to which BMI shares common influences with other methods of body fatness assessment. Age and gender were included in the analyses as covariates. The effect of age on estimates of the proportion of variance due to G, C and E could be assessed due to lack of statistical power, however a previous study found that BMI heritability estimates did not change significantly as individuals aged [46]. The following series of models was applied to the multivariate analysis of each variable group; each represents a different possible set of relationships between the observed variables and the latent (unmeasured) factors: Cholesky decomposition; independent pathway; and a one-, two- and three-factor common pathway. These models were compared on the basis of likelihood and parsimony to determine the model with the best fit. The difference in likelihood was assessed by calculating the difference in  $-2\ln L$  between models. Parsimony was assessed by Akaike's Information Criterion (AIC), which may be computed as  $-2\ln L - 2df$ , where the more negative value indicated the most parsimonious model. Heritability estimates from the best-fitting models were compared across body fatness expressions (percent body fat, fat mass, and fat mass/height<sup>2</sup>) using likelihood ratio tests.

A Cholesky decomposition model is used to estimate the genetic and environmental covariances across the multiple variables [25]. In this approach, the observed variables are influenced by  $n$  latent G factors,  $n$  latent C factors, and  $n$  latent E factors, where  $n$  equals the number of observed variables. The model is specified such that the first genetic factor influences all variables, the second genetic factor influences the final  $(n-1)$  variables, the third genetic factor influences the final  $(n-2)$  variables, and so on. Similar relationships exist for the common and unique environmental factors. This model is 'saturated' in that it estimates all genetic and environmental variances and covariances subject to the constraint that the matrices of these variance components are nonnegative definite.

The independent pathway model is specified so that common latent factors ( $G_C$ ,  $C_C$ , and  $E_C$ ) affect all of the observed variables. In addition, there are  $n$  specific latent G factors ( $G_S$ ),  $n$

specific latent C factors ( $C_S$ ), and  $n$  specific latent E factors ( $E_S$ ), where  $n$  equals the number of variables. These specific factors each affect only one observed variable.

In the common pathway model, a common latent factor influences all of the observed variables; this common factor is in turn influenced by G, C and E latent factors. Similar to the independent pathway model, variable-specific latent G, C, and E factors are also represented for each of the observed variables. The two-factor and three-factor common pathway models extend the common pathway model to include two or three common latent factors, each of which is influenced by a unique set of G, C and E latent factors.

To determine the most appropriate single measure of body fatness heritability, we focused on the contribution of specific genetic factors to variable variance. A small amount of variance due to specific genetic factors would indicate that little of the genetic variance was specific to the methodology and, instead, nearly all of the variance was accounted for by the common factors that theoretically capture influences on all measures of body fatness.

## RESULTS

Table 1 shows descriptive statistics of the study population. The majority of the subjects were female (72% of MZAs and 76% of MZTs) and Caucasian (97% of MZAs and 94% of MZTs). The mean age of the MZA twins ( $49.1 \pm 12.0$  years, range of 22–76 years) was significantly different from that of the MZT twins ( $28.7 \pm 7.3$  years, range of 18–47 years) ( $p < 0.05$ ). MZAs and MZTs differed significantly in percent body fat and fat mass/height<sup>2</sup> measured by all methods ( $p < 0.05$ ), but not when data were adjusted for age ( $p > 0.05$ ). Body composition methodology resulted in statistically significant differences in percent body fat and fat mass/height<sup>2</sup> ( $p < 0.0001$ , repeated measures analysis of variance), with DXA giving the highest values of percent body fat for both MZAs and MZTs, and skinfold thickness and underwater weighing giving the lowest values of percent body fat, for MZAs and MZTs respectively.

Table 2 shows the intrapair correlations for MZAs and MZTs. MZT correlations were greater than MZA correlations for all fatness variables, suggesting that common environmental factors play a role in body fatness. MZA correlations, which provide a direct estimate of heritability, ranged from 52–81% for fat mass/height<sup>2</sup>. However, as mentioned earlier, this technique of heritability estimation is inferior to model-fitting analyses [41].

Multivariate model-fitting analyses comparing body fatness measured by different body composition methods were performed in order to determine the extent to which measures from different body composition methods share genetic and environmental influences. Variance-covariance and correlation matrices for fat mass/height<sup>2</sup> and BMI are reported in the Supplementary Information, Appendix A. Table 3 shows goodness-of-fit data for the five models tested for transformed fat mass/height<sup>2</sup> and transformed BMI. Goodness-of-fit data for the other two variable groups (percent body fat and BMI, and fat mass and BMI) are not shown. However, the three-factor common pathway model was the best fit to the data for all three variable groups. Fig. (2) summarizes the components of variance of fat mass and BMI, as derived from the three-factor common pathway model. All three variable groups are

represented, allowing for comparison between different expressions of body fatness. Since body fatness is most commonly expressed as percent body fat, and as previously stated, we concluded that fat mass/height<sup>2</sup> was the most appropriate expression of body fatness, the comparison of results between expression as percent body fat and expression as fat mass/height<sup>2</sup> was of particular interest. Heritability estimates of percent body fat were significantly higher, by an average of 10.3%, than heritability estimates of fat mass/height<sup>2</sup> (LRT chisq=14.105; df=5; p=0.015)

Path diagrams of the multivariate analyses provide further information about the contribution of latent (unmeasured) factors, and in particular, shared and specific genetic and environmental influences on the observed measures. A path diagram for body fatness (expressed as fat mass/height<sup>2</sup>) and BMI is shown in Fig. (3). Standardized parameter estimates are printed along the paths, and statistically significant paths are represented as darkened lines, showing that all six observed variables share common influences: a factor that is primarily affected by genetic influences, a factor that is primarily affected by common environmental influences, and a factor that is primarily affected by unique environmental influences. A combination of specific latent genetic and environmental factors contributed significantly to the variance of all the observed variables except body fatness measured by DXA. Confidence intervals of the standardized parameter estimates of the body fatness three-factor common pathway model are reported in the Supplementary Information, Appendix B. Heritability estimates for body fatness were significantly different across the six body composition methods (LRT chisq=25.679; df=5; p<0.001), as were estimates of the proportion of variance due to common environmental factors (LRT chisq=20.603; df=5; p=0.001). Estimates of the proportion of variance due to unique environmental factors were not significantly different across the six body composition methods (LRT chisq=6.202; df=5; p=0.287), and a constrained model equating the six values resulted in an estimate of 16%.

We focused on the contribution of specific genetic factors to variable variance to determine the body composition method that produced the least biased heritability estimate of fat mass/height<sup>2</sup>. Although statistically nonsignificant, the specific genetic component was lowest for body fatness measured by DXA and total body water (0.04 and 0.07, respectively), indicating that nearly all of the genetic variance of these variables was accounted for by the common factors. Therefore, DXA and total body water appear to be the most appropriate body composition methods for heritability analyses of body fatness, introducing the least method-specific genetic variance into heritability estimates. The heritability estimates of body fatness measured by DXA and total body water were not significantly different from one another (LRT chisq=0.430; df=1; p=0.512), and were higher than heritability estimates of body fatness measured by BIA, skinfold thickness and BMI, and lower than the heritability estimate of body fatness measured by underwater weighing. A model in which the heritability of body fatness measured by DXA was constrained to equal that measured by total body water produced a joint heritability estimate of 60%. Similarly, estimates of the proportion of variance due to common environmental factors were not significantly different between the DXA and total body water variables (LRT chisq=0.006; df=1; p=0.939), and a model constraining these two values to be equal produced an estimate of 22%. Although estimates of the proportion of variance due to

unique environmental factors were very similar between the DXA and total body water variables (22% for DXA and 17% for total body water), they were significantly different (LRT  $\chi^2=5.643$ ;  $df=1$ ;  $p=0.018$ ). A model with these two values equated produced an estimate of 18%, although it fit significantly more poorly than when they were not equated. These estimates are summarized in Table 4.

## DISCUSSION AND CONCLUSION

The estimated heritability of body fatness has varied widely in previous studies, with values ranging from 45 to 90% [6–18]. In part, this variability is likely due to methodology differences among investigations. Specifically, several different body composition techniques and expressions of body fatness have been used and little is known about the impact of these differences. In this study, for the first time, we directly compared data on body fatness obtained by using six common body composition techniques and found significant effects of body composition methodology and body fatness expression on heritability estimates. DXA and total body water expressed as fat mass/height<sup>2</sup> appeared to be the methods with least measure-specific genetic variance, based on theoretical considerations and also on the finding that little of these measures' variance was due to specific genetic factors. Compared to the classic body composition assessment – percent body fat measured by underwater weighing – fatness expressed as fat mass/height<sup>2</sup> and measured using DXA and total body water gave lower estimates of heritability (60% versus 78%) and higher estimates for common environmental contributors to variance (22% versus 4%). These results suggest a reduced role for genetics and a greater contribution of common environmental influences on body fatness than suggested in some previous studies.

The selection of DXA and total body water as the most appropriate methods to assess the heritability of body fatness is supported by the higher precision of these two methods (approximately 2% and 3% for DXA and total body water, respectively), compared to other body composition methods, particularly underwater weighing and skinfold thickness (approximately 3–4% and 5%, respectively) [47]. The lower precision of underwater weighing and skinfold thickness is likely attributed to variation in water content and bone density (for underwater weighing) and skill of the anthropometrist and size of the skinfold (for skinfold thickness) [47]. Although we did not measure test-retest reliability of body composition methods, differences in test-retest reliability between methods are probably not a major cause of the difference between the heritability estimates of fat mass/height<sup>2</sup> measured by DXA and total body water and the fat mass/height<sup>2</sup> measured by underwater weighing. Previous reports have shown that DXA, total body water and underwater weighing all have high test-retest reliability (Cronbach's  $\alpha$  of 0.999, 0.986, 0.992, respectively) [48].

The finding that the classic body composition technique, underwater weighing, yielded a higher heritability of body fatness compared to DXA and total body water was not unexpected based on theoretical consideration of the method, but the size of the difference was substantial (for fat mass/height<sup>2</sup>: underwater weighing and DXA LRT  $\chi^2=9.249$ ,  $df=1$ ,  $p=0.002$ ; underwater weighing and total body water LRT  $\chi^2=3.663$ ,  $df=1$ ,  $p=0.056$ ). There are several aspects of the method that may have contributed to the genetic

bias. In particular, underwater weighing involves estimating the underwater weight of the subject after predicting the amount of buoyant air remaining in the lungs, and estimates for residual lung volume can be obtained (as in this study) using a regression equation involving sex, height, and age [30]. Since height is highly correlated among monozygotic twins (intra-class correlations of 0.94 for MZTs and 0.96 for MZAs in this population), the use of the equation likely inflated body fatness concordance and hence increased heritability estimates. In addition, bone mineral density is another factor that is known to be variable and heritable [49], but the underwater weighing method assumes that this factor is constant (relative to FFM) between individuals. Skinfold thickness and BIA are other widely-used body composition techniques favored for their simplicity, but in this study, they estimated heritability to be approximately 12% less than that of fat mass/height<sup>2</sup> measured by DXA and total body water, perhaps by introducing more measurement error. Concerning BMI, values for heritability were also lower (by 6%) than values obtained for fat mass/height<sup>2</sup> by DXA and total body water, perhaps because of increased variability associated with the heritability of fat-free mass within the same parameter.

The statistically significant effect of body fatness expression (percentage vs. fat mass/height<sup>2</sup>) on heritability estimates was also not unexpected since different expressions incorporate other parameters (FFM and height) that may influence heritability estimates. Consistent with our finding that expression as percent body fat estimates the heritability of body fatness to be 10.3% greater than when fat mass/height<sup>2</sup> is used, previous studies expressing body fatness as percent body fat have reported heritability estimates ranging from 55–83% [7–13], which are generally higher than our heritability estimate of 60% for fat mass/height<sup>2</sup>. This difference is likely due, at least in part, to the indirect incorporation of FFM when body fatness is expressed as a percentage of body weight. Additionally, previous studies expressing body fatness as fat mass have generally reported higher heritability estimates of body fatness (ranging from 45–71%)[10, 14–18] compared with our estimate of 60%, which is consistent with our finding that expression as fat mass overestimates the heritability of body fatness by 3.1% compared to expression as fat mass/height<sup>2</sup>. Although height adjustment was not necessary in this population, the minimal albeit significant effect of height adjustment on the heritability of body fatness led us to conclude that body fatness expression as fat mass/height<sup>2</sup> is the most appropriate expression because it is consistent with BMI and FFM/height<sup>2</sup>, the height-adjusted expression of body leanness.

The relatively modest heritability of body fatness compared to other anthropometric parameters such as height, arm span, and chest circumference [50, 51] suggests that differences in body fatness between people are influenced by environmental factors almost as much as by genetic inheritance. The search for genes associated with obesity has recently received considerable attention [52–54], and while a body fatness heritability estimate of 60% supports that ongoing search, the impact of environmental factors on body fatness should not be overlooked. Many overweight therapies aimed at changing individuals' environments could, and probably do, have a substantial impact on differences in body fatness between people. Although we assessed the relative contributions of genetic and environmental influences on body fatness, in this study our aim was not to identify the specific influences. However, it is well established that high energy intake, low energy expenditure for physical activity, and factors that influence these behaviors are among the

environmental influences that lead to increases in body fatness [3]. As described elsewhere, further research will provide more insight into the most successful obesity therapies [4].

As described elsewhere [4], the results of this study should be interpreted within the context of several limitations. First, the relatively small sample size of this study may have been insufficient to detect statistically significant estimates, were they to exist. Second, our results may not be generalizable to other cohorts. Third, cultural differences between Western Countries may affect results. Fourth, the potential violation of one or more of the MZA/MZT twin model assumptions, which were previously described, could affect results. However, assumptions of the MZA/MZT twin model are standard and can potentially be tested in future studies [42].

In conclusion, this study of body fatness heritability in a unique population of MZAs and MZTs showed a lower heritability estimate (60%) and a higher estimate of the proportion of variance due to common and unique environmental factors (22% and 18%, respectively) than many previous studies. This difference can be attributed to the identification of appropriate body composition methods and expressions (DXA and total body water with fatness expressed as fat mass/height<sup>2</sup>) to minimize bias. Body fatness measured using these techniques appears to be substantially less heritable than other body parameters such as height and chest circumference, emphasizing the importance of environmental factors and possibly genotype by environmental interactions in the etiology of weight gain and the obesity epidemic.

## Supplementary Material

Refer to Web version on PubMed Central for supplementary material.

## Acknowledgments

We thank the volunteers who participated in this study, Angela Vinken for her assistance with data collection, Dr. Gerard E. Dallal and Dr. Hermine H. M. Maes for their statistical assistance during manuscript preparation, Dr. Joseph Kehayias for his consultation on body composition methodology, and Brenda Roche for her assistance in data preparation. Funding support for this project was provided by NIH funding (DK046124, DK79003, DK76092, DK78867, MH65322, DA18673, F32 DK009747, and 5T32 HL069772) and the U.S. Department of Agriculture under agreements no. 1950-51000-061-04S and 1950-51000-061-05S. Any opinions, findings, conclusions, or recommendations expressed in this publication are those of the authors and do not necessarily reflect the view of the U.S. Department of Agriculture.

## REFERENCES

1. Hedley AA, Ogden CL, Johnson CL, Carroll MD, Curtin LR, Flegal KM. Overweight and obesity among US children, adolescents, and adults 1999–2002. *JAMA*. 2004; 291:2847–2850. [PubMed: 15199035]
2. World Health Organization. Geneva: World Health Organization World Health Org; 2006 Sep. Obesity and overweight: Fact sheet No. 311; p. 1-3.
3. Martinez JA. Body-weight regulation: causes of obesity. *Proc Nutr Soc*. 2000; 59:337–345. [PubMed: 10997649]
4. Elder JS, Lichtenstein AH, Pittas AG, et al. Genetic and environmental influences on factors associated with cardiovascular disease and the metabolic syndrome. *J Lipid Res*. 2009; 50:1917–1926. [PubMed: 19372593]

5. Plomin, R.; DeFries, JC.; McClearn, GE.; Rutter, M. Behavioral genetics. 3rd ed.. New York: W.H. Freeman and Company; 1997.
6. Maes HH, Neale MC, Eaves LJ. Genetic and environmental factors in relative body weight and human adiposity. *Behav Genet.* 1997; 27:325–351. [PubMed: 9519560]
7. Bo S, Cavallo-Perin P, Scaglione L, Pagano G. Heritability of cardiovascular risk parameters in subjects with increased susceptibility to non-insulin-dependent diabetes mellitus. *Acta Diabetol.* 1997; 34:280–284. [PubMed: 9451473]
8. Rice T, Daw EW, Gagnon J, et al. Familial resemblance for body composition measures: the HERITAGE Family Study. *Obes Res.* 1997; 5:557–562. [PubMed: 9449140]
9. Schousboe K, Visscher PM, Erbas B, et al. Twin study of genetic and environmental influences on adult body size, shape, and composition. *Int J Obes Relat Metab Disord.* 2004; 28:39–48. [PubMed: 14610529]
10. Hsu FC, Lenchik L, Nicklas BJ, et al. Heritability of body composition measured by DXA in the diabetes heart study. *Obes Res.* 2005; 13:312–319. [PubMed: 15800289]
11. Malis C, Rasmussen EL, Poulsen P, et al. Total and regional fat distribution is strongly influenced by genetic factors in young and elderly twins. *Obes Res.* 2005; 13:2139–2145. [PubMed: 16421348]
12. Bayoumi RA, Al-Yahyaee SA, Albarwani SA, et al. Heritability of determinants of the metabolic syndrome among healthy Arabs of the Oman family study. *Obesity.* 2007; 15:551–556. [PubMed: 17372303]
13. Rasmussen-Torvik LJ, Pankow JS, Jacobs DR, et al. Heritability and genetic correlations of insulin sensitivity measured by the euglycaemic clamp. *Diabet Med.* 2007; 24:1286–1289. [PubMed: 17956454]
14. Forbes GB, Sauer EP, Weitkamp LR. Lean body mass in twins. *Metabolism.* 1995; 44:1442–1446. [PubMed: 7476332]
15. Samaras K, Spector TD, Nguyen TV, Baan K, Campbell LV, Kelly PJ. Independent genetic factors determine the amount and distribution of fat in women after the menopause. *J Clin Endocrinol Metab.* 1997; 82:781–785. [PubMed: 9062482]
16. Nguyen TV, Howard GM, Kelly PJ, Eisman JA. Bone mass, lean mass, and fat mass: same genes or same environments? *Am J Epidemiol.* 1998; 147:3–16. [PubMed: 9440393]
17. Samaras K, Nguyen TV, Jenkins AB, et al. Clustering of insulin resistance, total and central abdominal fat: same genes or same environment? *Twin Res.* 1999; 2:218–225. [PubMed: 10555133]
18. Hanisch D, Dittmar M, Hohler T, Alt KW. Contribution of genetic and environmental factors to variation in body compartments—a twin study in adults. *Anthropol Anz.* 2004; 62:51–60. [PubMed: 15109035]
19. Allison DB, Kaprio J, Korkeila M, Koskenvuo M, Neale MC, Hayakawa K. The heritability of body mass index among an international sample of monozygotic twins reared apart. *Int J Obes Relat Metab Disord.* 1996; 20:501–506. [PubMed: 8782724]
20. MacDonald A, Stunkard A. Body-mass indexes of British separated twins. *N Engl J Med.* 1990; 322:1530. [PubMed: 2336081]
21. Stunkard AJ, Harris JR, Pedersen NL, McClearn GE. The body-mass index of twins who have been reared apart. *N Engl J Med.* 1990; 322:1483–1487. [PubMed: 2336075]
22. Price RA, Gottesman II. Body fat in identical twins reared apart: roles for genes and environment. *Behav Genet.* 1991; 21:1–7. [PubMed: 2018460]
23. Hong Y, Pedersen NL, Brisman K, de Faire U. Genetic and environmental architecture of the features of the insulin-resistance syndrome. *Am J Hum Genet.* 1997; 60:143–152. [PubMed: 8981957]
24. Nelson TL, Vogler GP, Pedersen NL, Hong Y, Miles TP. Genetic and environmental influences on body fat distribution, fasting insulin levels and CVD: are the influences shared? *Twin Res.* 2000; 3:43–50. [PubMed: 10808240]
25. Neale, MC.; Cardon, LR. Methodology for genetic studies of twins and families. Boston: Kluwer Academic Publishers; 1992.

26. Bouchard TJ Jr, Lykken DT, McGue M, Segal NL, Tellegen A. Sources of human psychological differences: the Minnesota Study of Twins Reared Apart. *Science*. 1990; 250:223–228. [PubMed: 2218526]
27. Johnson J, Dawson-Hughes B. Precision and stability of dual-energy X-ray absorptiometry measurements. *Calcif Tissue Int*. 1991; 49:174–178. [PubMed: 1933582]
28. Ellis KJ. Human body composition: *in vivo* methods. *Physiol Rev*. 2000; 80:649–680. [PubMed: 10747204]
29. Moriguti JC, Das SK, Saltzman E, et al. Effects of a 6-week hypocaloric diet on changes in body composition, hunger, and subsequent weight regain in healthy young and older adults. *J Gerontol A Biol Sci Med Sci*. 2000; 55:B580–B587. [PubMed: 11129387]
30. Quanjer PH, Tammeling GJ, Cotes JE, Pedersen OF, Peslin R, Yernault JC. Lung volumes and forced ventilatory flows. *Eur Respir J Suppl*. 1993; 16:5–40. [PubMed: 8499054]
31. Siri, WE. Body composition from fluid spaces and density: analysis of methods. In: Brozek, J.; Henschel, A., editors. *Techniques for measuring body composition*. Washington DC: National Academy of Sciences; 1961. p. 223-244.
32. Fields DA, Goran MI, McCrory MA. Body-composition assessment *via* air-displacement plethysmography in adults and children: a review. *Am J Clin Nutr*. 2002; 75:453–467. [PubMed: 11864850]
33. Yao M, Roberts SB, Ma G, Pan H, McCrory MA. Field methods for body composition assessment are valid in healthy chinese adults. *J Nutr*. 2002; 132:310–317. [PubMed: 11823597]
34. Racette SB, Schoeller DA, Luke AH, Shay K, Hnilicka J, Kushner RF. Relative dilution spaces of 2H- and 18O-labeled water in humans. *Am J Physiol*. 1994; 267:E585–E590. [PubMed: 7943308]
35. Pace N, Rathbun E. Studies on body composition. III. The body water and chemically combined nitrogen content in relation to fat content. *J Biol Chem*. 1945; 158:685–691.
36. Lukaski HC, Bolonchuk WW, Hall CB, Siders WA. Validation of tetrapolar bioelectrical impedance method to assess human body composition. *J Appl Physiol*. 1986; 60:1327–1332. [PubMed: 3700310]
37. Gibson, RS. *Principles of nutritional assessment*. New York: Oxford University Press; 1990.
38. Durnin JV, Womersley J. Body fat assessed from total body density and its estimation from skinfold thickness: measurements on 481 men and women aged from 16 to 72 years. *Br J Nutr*. 1974; 32:77–97. [PubMed: 4843734]
39. SAS Institute Inc. *SAS/STAT 9.1 User's Guide*. Cary, NC: SAS Institute Inc; 2004.
40. SPSS Inc. *SPSS 15.0 Brief Guide*. Chicago, IL: SPSS, Inc; 2006.
41. Neale, MC. Twin studies: software and algorithms. In: Cooper, DN., editor. *Encyclopedia of the human genome*. London: Macmillan Publishers Ltd, Nature Publishing Group; 2003.
42. Neale, MC. Twin analysis. In: Armitage, P.; Colton, T., editors. *Encyclopedia of biostatistics*. New York: John Wiley; 1998.
43. Neale, MC.; Boker, SM.; Xie, G.; Maes, HH. *Mx: Statistical modeling*. 6th ed.. Richmond, VA 23298: Virginia Commonwealth University: Department of Psychiatry, VCU Box 900126; 2003.
44. Sham, PC. *Statistics in human genetics*. New York: John Wiley & Sons; 1997.
45. Dominicus A, Skrandal A, Gjessing HK, Pedersen NL, Palmgren J. Likelihood ratio tests in behavioral genetics: problems and solutions. *Behav Genet*. 2006; 36:331–340. [PubMed: 16474914]
46. Stunkard AJ, Foch TT, Hrubec Z. A twin study of human obesity. *JAMA*. 1986; 256:51–54. [PubMed: 3712713]
47. Lukaski HC. Methods for the assessment of human body composition: traditional and new. *Am J Clin Nutr*. 1987; 46:537–556. [PubMed: 3310598]
48. Friedl KE, DeLuca JP, Marchitelli LJ, Vogel JA. Reliability of body-fat estimations from a four-compartment model by using density, body water, and bone mineral measurements. *Am J Clin Nutr*. 1992; 55:764–770. [PubMed: 1550056]
49. Videman T, Levalhti E, Battie MC, Simonen R, Vanninen E, Kaprio J. Heritability of BMD of femoral neck and lumbar spine: a multivariate twin study of Finnish men. *J Bone Miner Res*. 2007; 22:1455–1462. [PubMed: 17547536]

50. Chatterjee S, Das N, Chatterjee P. The estimation of the heritability of anthropometric measurements. *Appl Hum Sci.* 1999; 18:1–7.
51. Macgregor S, Cornes BK, Martin NG, Visscher PM. Bias, precision and heritability of self-reported and clinically measured height in Australian twins. *Hum Genet.* 2006; 120:571–580. [PubMed: 16933140]
52. Saunders CL, Chiodini BD, Sham P, et al. Meta-analysis of genome-wide linkage studies in BMI and obesity. *Obesity (Silver Spring).* 2007; 15:2263–2275. [PubMed: 17890495]
53. Ichihara S, Yamada Y. Genetic factors for human obesity. *Cell Mol Life Sci.* 2008; 65:1086–1098. [PubMed: 18097636]
54. Segal NL. New sources of reared apart twins research reviews: female fitness in male-female twin pairs, heritability of olfactory thresholds and the Twelfth International Twin Congress; multiple birth conceptions: rethinking things; double donations. *Twin Res Hum Genet.* 2007; 10:786–790. [PubMed: 17903122]

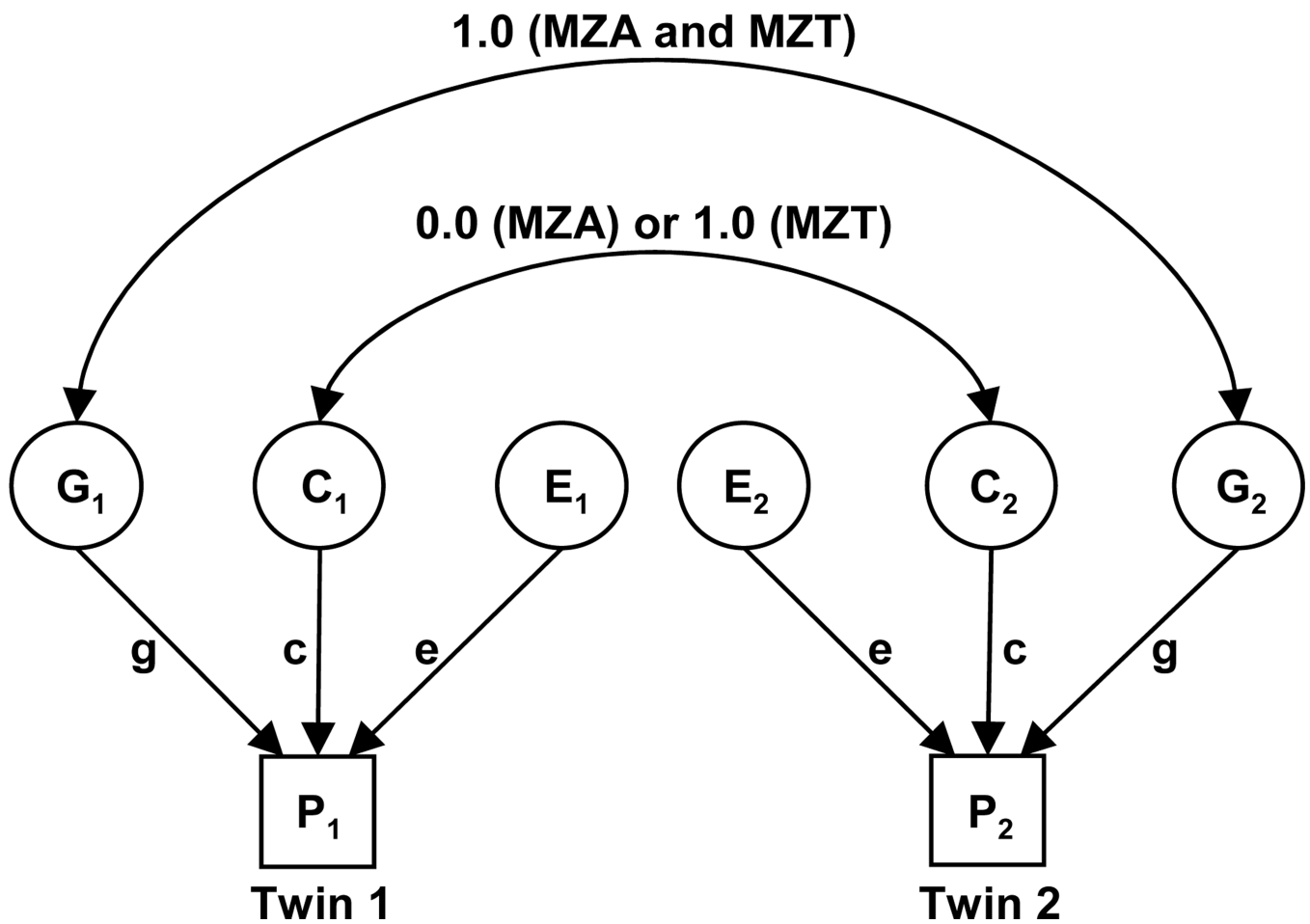

**Fig. (1).** Path diagram of the univariate MZA/MZT GCE twin model. MZA, monozygotic twins reared apart; MZT, monozygotic twins reared together; G, genetic factors; C, common environmental factors; E, unique environmental factors; g, c, e are path coefficients;  $P_1$ , phenotype of twin 1;  $P_2$ , phenotype of twin 2. Circles represent latent (unmeasured) variables. Squares represent observed (measured) variables. Single-headed arrows represent hypothesized casual relationships between variables. Double-headed arrows represent correlation or covariance between variables.

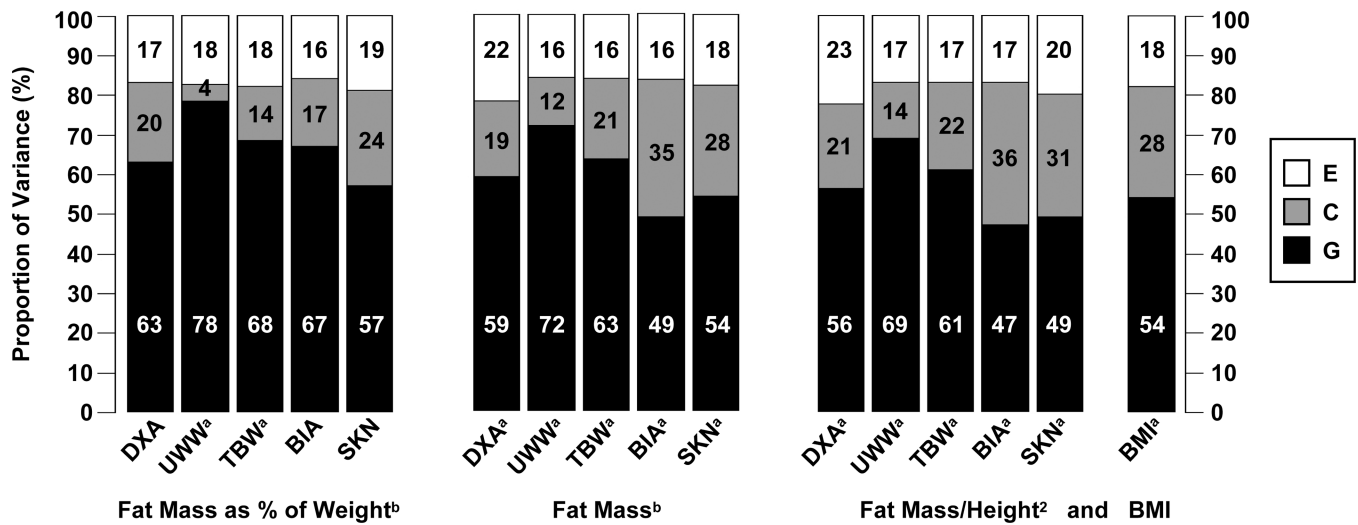
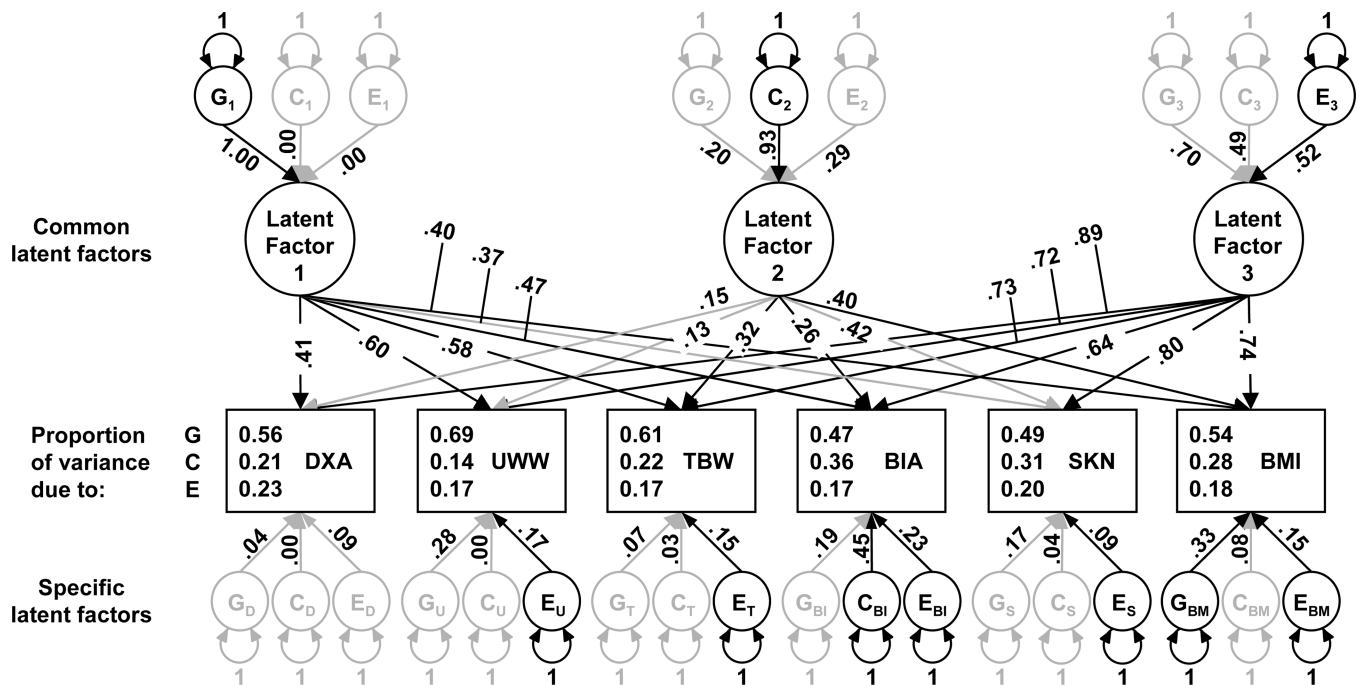

Fig. (2).

Components of variance of fat mass and body mass index as assessed by the three-factor common pathway model. <sup>a</sup>Variable was transformed as (100 × natural log of variable). <sup>b</sup>BMI was included in the multivariate analyses, but results are not shown because BMI results were similar to results from fat mass/height<sup>2</sup> analysis. DXA, dual energy x-ray absorptiometry; UWW, underwater weighing; TBW, total body water; BIA, bioelectric impedance; SKN, skin thickness; BMI, body mass index; G, genetic; C, common environmental; E, unique environmental.



**Fig. (3).** Three-factor common pathway model path diagram of body fatness (fat mass/height<sup>2</sup> and BMI). Rectangles represent observed variables. Circles represent latent or unmeasured variables. Single-headed arrows represent hypothesized casual relationships between variables. Double-headed arrows represent variance. Path coefficients are standardized parameter estimates. Confidence intervals of estimates are reported in the Supplementary Information, Appendix B. G, genetic factors; C, common environmental factors; E, unique environmental factors. Darkened lines indicate significant paths. Subscripts indicate variable or factor under influence. Observed variables were 100 × natural log of fat mass/height<sup>2</sup> measured by dual energy x-ray absorptiometry (DXA), underwater weighing (UWW), total body water (TBW), bioelectric impedance (BIA), skinfold thickness (SKN), and 100 × natural log of mass/height<sup>2</sup> (BMI).

**Table 1**

## Characteristics of Study Population

	Mean $\pm$ s.d. (n <sup>a</sup> )		P <sup>b</sup>
	MZA	MZT	
Age (years)	49.1 $\pm$ 12.0 (58)	28.7 $\pm$ 7.3 (99)	<0.0001
Weight (kg)	75.3 $\pm$ 18.8 (58)	66.1 $\pm$ 11.1 (99)	0.0047 <sup>c</sup>
Height (cm)	166.3 $\pm$ 9.3 (58)	169.6 $\pm$ 7.6 (99)	0.0794
BMI (kg/m <sup>2</sup> )	27.0 $\pm$ 5.2 (58)	23.0 $\pm$ 3.2 (99)	<0.0001 <sup>c</sup>
PBF DXA (%)	35.2 $\pm$ 8.9 (52)	27.4 $\pm$ 8.2 (97)	0.0001 <sup>c</sup>
PBF UWW (%)	32.7 $\pm$ 11.4 (41)	23.6 $\pm$ 8.5 (97)	0.0001 <sup>c</sup>
PBF TBW (%)	34.8 $\pm$ 8.7 (54)	27.5 $\pm$ 8.7 (95)	<0.0001 <sup>c</sup>
PBF BIA (%)	32.9 $\pm$ 10.5 (40)	25.7 $\pm$ 7.6 (85)	0.0019 <sup>c</sup>
PBF SKN (%)	30.6 $\pm$ 7.0 (58)	26.9 $\pm$ 6.2 (99)	0.0096 <sup>c</sup>
FAT/HT <sup>2</sup> DXA (kg/m <sup>2</sup> )	9.9 $\pm$ 3.9 (52)	6.6 $\pm$ 2.7 (97)	<0.0001 <sup>c</sup>
FAT/HT <sup>2</sup> UWW (kg/m <sup>2</sup> )	9.1 $\pm$ 4.5 (41)	5.6 $\pm$ 2.7 (97)	<0.0001 <sup>c</sup>
FAT/HT <sup>2</sup> TBW (kg/m <sup>2</sup> )	9.7 $\pm$ 3.9 (54)	6.5 $\pm$ 2.8 (95)	<0.0001 <sup>c</sup>
FAT/HT <sup>2</sup> BIA (kg/m <sup>2</sup> )	9.3 $\pm$ 4.4 (40)	6.0 $\pm$ 2.6 (85)	0.0002 <sup>c</sup>
FAT/HT <sup>2</sup> SKN (kg/m <sup>2</sup> )	8.5 $\pm$ 3.2 (58)	6.2 $\pm$ 2.1 (99)	<0.0001 <sup>c</sup>

MZA, monozygotic twins reared apart; MZT, monozygotic twins reared together; DXA, dual energy x-ray absorptiometry; UWW, underwater weighing; TBW, total body water; BIA, bioelectric impedance; SKN, skinfold thickness; PBF, percent body fat; FAT/HT<sup>2</sup>, (fat mass in kg)/(height in m)<sup>2</sup>.

Body composition methodology resulted in statistically significant differences in percent body fat and fat mass/height<sup>2</sup>, ( $p < 0.0001$ , repeated measures analysis of variance).

<sup>a</sup> n, number of individuals.

<sup>b</sup> P for statistical difference between MZA and MZT twins corrected for sampling among twins.

<sup>c</sup> Differences between MZA and MZT means were not statistically significant when adjusting for age, age<sup>2</sup>, and age<sup>3</sup> ( $P > 0.05$ ).

**Table 2**

## Intrapair MZA and MZT Correlations

	MZA		MZT	
	n <sup>a</sup>	Intrapair Correlation (95% CI)	n <sup>a</sup>	Intrapair Correlation (95% CI)
Weight (kg)	29	0.69 (0.45, 0.84)	49	0.87 (0.79, 0.93)
Height (cm)	29	0.96 (0.92, 0.98)	49	0.94 (0.90, 0.97)
tr BMI	29	0.65 (0.38, 0.82)	49	0.80 (0.66, 0.88)
tr FAT/HT <sup>2</sup> DXA	25	0.66 (0.37, 0.84)	48	0.80 (0.67, 0.88)
tr FAT/HT <sup>2</sup> UWW	19	0.81 (0.57, 0.92)	48	0.83 (0.72, 0.90)
tr FAT/HT <sup>2</sup> TBW	25	0.59 (0.27, 0.80)	45	0.85 (0.74, 0.91)
tr FAT/HT <sup>2</sup> BIA	20	0.52 (0.11, 0.77)	42	0.82 (0.70, 0.90)
tr FAT/HT <sup>2</sup> SKN	29	0.64 (0.36, 0.81)	49	0.83 (0.72, 0.90)

MZA, monozygotic twins reared apart; MZT, monozygotic twins reared together; CI, confidence interval; tr, variable transformed by multiplying the natural log of the variable by 100; FAT/HT<sup>2</sup>, (fat mass in kg)/(height in m)<sup>2</sup>; DXA, dual energy x-ray absorptiometry; UWW, underwater weighing; TBW, total body water; BIA, bioelectric impedance; SKN, skinfold thickness.

<sup>a</sup> n, number of twin pairs.

**Table 3**  
 Test of Multivariate Models for Transformed Fat Mass/Height<sup>2</sup> and Transformed Body Mass Index

	Fit Statistics					
	-2lnL	df	$\chi^2$	df	P	AIC
1. Cholesky decomposition	6811	794				5223
2. Independent pathway model	6857	821	46	27	0.013	5215
3. Common pathway model	6904	831	94	37	0.000	5242
4. 2-Factor common pathway model	6865	825	55	31	0.005	5215
5. 3-Factor common pathway model	6845	821	35	27	0.149	5203

lnL, log-likelihood; df, degrees of freedom;  $\chi^2$ , difference chi-squared compared to Cholesky decomposition; df, difference degrees of freedom compared to Cholesky decomposition; P for statistical difference compared to Cholesky decomposition; AIC, Akaike's information criterion.

Variables were transformed fat mass ( $100 \times \ln$  of mass/height<sup>2</sup>) measured by dual energy x-ray absorptiometry, underwater weighing, total body water, bioelectric impedance, skinfold thickness and transformed body mass index ( $100 \times \ln$  of mass/height<sup>2</sup>).

**Table 4**Contribution of Genetic and Environmental Factors to Body Fatness (Fat Mass/Height<sup>2</sup>) Variance

	Proportion of Variance
Genetic (G)	60%
Common Environmental (C)	22%
Unique Environmental (E)	18%

Estimates assessed by a constrained model equating proportion of variance due to G,C, or E factors across dual energy x-ray absorptiometry and total body water measures of fat mass/height<sup>2</sup>, since we found these methods to produce the least biased estimates of heritability.