

2022-06-13

Photon-Pair Generation in a 45 nm CMOS Microring Cavity: Impact of Spontaneous Raman Scattering

A. Ramesh, I. Wang, D. Kramnik, J.M. Fargas-Cabanillas, V. Stojanovic, M. Popovic, P. Kumar.
2022. "Photon-Pair Generation in a 45 nm CMOS Microring Cavity: Impact of Spontaneous Raman Scattering." Quantum 2.0. Boston, MA, 2022-06-13 - 2022-06-16.

<https://hdl.handle.net/2144/45186>

"Downloaded from OpenBU. Boston University's institutional repository."

Photon-Pair Generation in a 45 nm CMOS Microring Cavity: Impact of Spontaneous Raman Scattering

Anirudh Ramesh^{1†}, Imbert Wang², Danielius Kramnik³, Josep M. Fargas Cabanillas², Vladimir Stojanović³, Miloš A. Popović², and Prem Kumar^{1‡}

¹Center for Photonic Communication and Computing, Dept. of Electrical and Computer Eng., Northwestern University, Evanston, IL 60208, USA

²Department of Electrical and Computer Engineering, Photonics Center, Boston University, Boston, MA 02215, USA

³Department of Electrical Engineering and Computer Science, UC Berkeley, Berkeley, CA 94720, US

[†]anirudh@u.northwestern.edu, [‡]kumarp@northwestern.edu

Abstract: We characterize the impact of spontaneous Raman scattering (SRS) on photon-pair generation via spontaneous four-wave mixing (SFWM) in a CMOS microring cavity by analyzing the single counts in each channel to separate out the contribution of SRS from SFWM. We find the contribution of SRS to the photon counts to be low compared to that from SFWM.

© 2022 The Author(s)

Photon-pair sources are key building blocks for quantum information technologies such as linear optics quantum computing and quantum communication [1, 2]. Integrated silicon photonics is widely considered to be a leading platform for such sources due to its small footprint and scalable high fidelity CMOS processes allowing rapid manufacturing and reconfigurability of these devices. Photon-pairs in silicon photonic devices are generated by spontaneous fourwave mixing (SFWM) as a result of the third-order ($\chi^{(3)}$) optical nonlinearity of crystalline silicon. Significant progress has been made in designing sources based on silicon microrings, with developments in integrated pump rejection filtering and closed-loop feedback stabilization of SFWM [3, 5, 6]. Two key metrics for such sources are the pair rate, which is important to maintain a high rate of quantum data transfer and the coincidences-to-accidentals ratio (CAR) which is crucial for a high quantum signal-to-noise ratio. The presence of amorphous silicon dioxide and silicon nitride in CMOS-based microrings as cladding materials for the waveguides leads to a strong possibility for generating spontaneous Raman scattered (SRS) photons along with the quantum-correlated photon pairs due to these materials' broadband Raman gain spectra. Such SRS photons degrade the CAR by creating more accidental coincidences. The device we analyze here is an electronic-photonic photon-pair source with integrated feedback-controlled frequency locking and filtering in 45 nm CMOS [8] shown in Fig. 1 (a). In our previous paper we measured a maximum CAR of ≈ 40 [6] and our motivation is to study the possibility of SRS contributing to a possible upper bound on the CAR.

Figure 1 (b) shows the experimental setup for the quantum characterization of the microrings. In addition to the cavity, there are also tunable pump cleanup and pump rejection filters present on the chip that are electronically

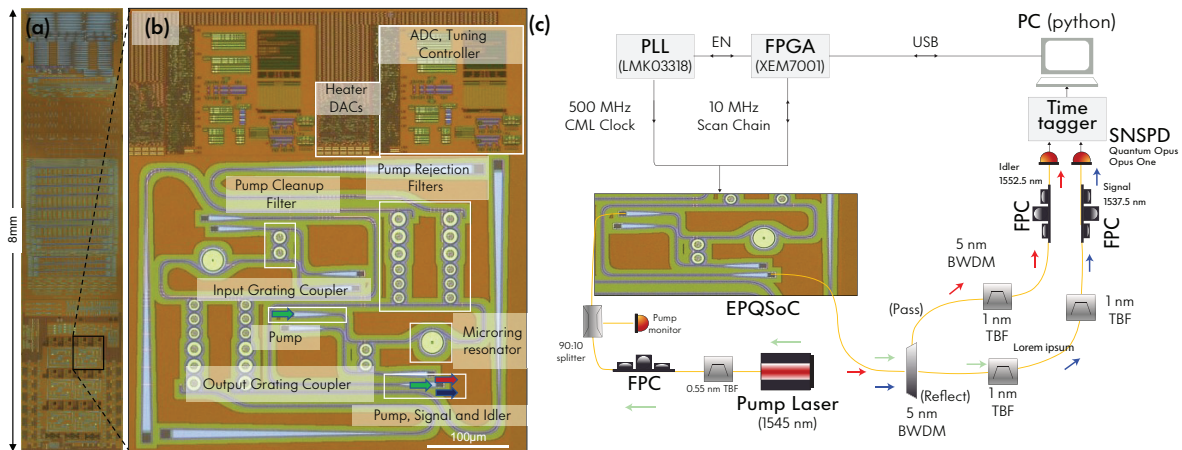

Fig. 1: (a) Die micrograph of the electronic-photonic quantum system-on-chip (EPQSoC). (b) Two interleaved electronic-photonic-quantum photon-pair generator system sites with control circuits on chip. For this experiment, we bypassed the on-chip tuning and filtering to analyze solely the microring resonator. (c) Experimental setup for measuring Raman, CAR, and coincidence rates with off-chip pump filtering. Using a system comprised of analog electronics and an FPGA, closed-loop control of SFWM is achieved by using the photocurrent as feedback to tune the heater and match the cavity resonance to the pump wavelength [6].

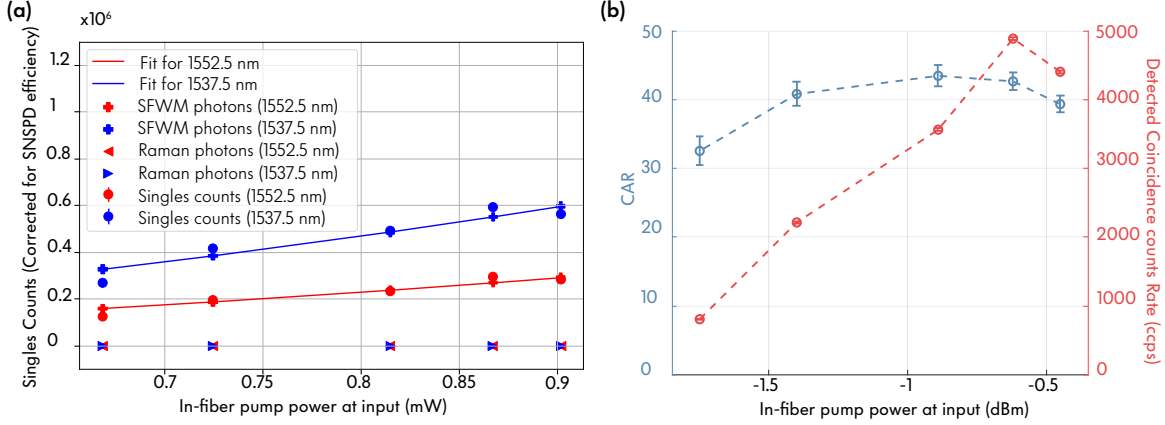

Fig. 2: (a) Singles counting results for this device along with the fit with Eq. (1), the SRS and Raman photons extracted from the fit, for the signal and idler channels, respectively, as a function of pump power. (b) Coincidence counting results with 10 ps bin widths integrated for 10 s as a function of in-fiber input power, with a 400 ps coincidence window.

controlled; however, for this experiment we bypass them and use off-chip filtering. Light from a continuous-wave (Santec TSL-210) laser is used to pump the microring cavity, after being filtered for in-band noise in the signal and idler channels. The microring contains interleaved p-i-n junctions for carrier sweepout to reduce free-carrier absorption and generate a photocurrent and a disk shaped heater that can be used to tune its resonance frequency. A 5-nm wide band wavelength division multiplexer (BWDM) separates the idler from the pump and signal photons which are further separated from the pump using three 1-nm wide tunable bandpass filters (TBF). Two Superconducting Nanowire Single Photon Detectors (SNSPD) operating at 50% quantum efficiency detect the generated photons. A time-to-digital converter records timestamps of the incoming photons and measures the coincidences. Source-locking electronics allows us to consistently align the cavity to the pump wavelength.

In the regime where the $\chi^{(3)}$ interaction is weak, the number of photons generated by SRS varies linearly with pump power whereas the number of photons generated by SFWM has a quadratic dependence [7]. The following expression [4] computes the number of photons n_u generated by the $\chi^{(3)}$ nonlinearity

$$n_u = \Delta v_u \int (|\gamma P_0 L|^2 + P_0 L |g_R| N_u) dt, \quad (1)$$

where u references to the channel, P_0 is the instantaneous pump power, Δv_u refers to the filter bandwidth (1 nm), γ is the Kerr nonlinear coefficient, g_R is the Raman gain, L is the interaction length, and N_u is the phonon population. By fitting the singles counts per channel to this expression, after subtracting the contribution of the detuned system and dark counts, we can calculate the fractions of Raman photons and biphotons to the singles counts in each channel. Figure 2(a) shows the singles counting results for this device with plots of the singles counts, the fit with Eq (1), the SRS and Raman photons extracted from the fit, for the signal and idler channels, respectively, as a function of the pump power. Constraining the fit for positive coefficients, clearly shows that the contribution of SRS to the single counts is negligible and the contribution of SFWM is dominant. Figure 2(b) is the plot of the coincidence counting for this chip, where we detect a maximum pair rate of ≈ 5000 ccps. The CAR trend indicates we have a maximum possible CAR of ≈ 40 for this ring. This indicates that the accidental counts are not dominated by SRS photons and that other noise-generating processes and filtering could be a dominant factor in restricting the CAR for such systems [6].

Acknowledgments: Work funded in part by NSF EQuIP grant 1842692, the Catalyst Foundation, and the ONR grant N000141410259.

References

1. J.W. Silverstone, *et al.*, "Silicon Quantum Photonics", IEEE J. Sel. Top. Quantum Electronics 22, 390-402 (2016).
2. T. Rudolph, "Why I am optimistic about the silicon-photonics route to quantum computing", APL Photonics 2, 030901 (2017).
3. C. Gentry, *et al.* "Quantum-correlated photon pairs generated in a commercial 45 nm complementary... ", Optica 2, 1065-1071 (2015).
4. Q. Linet *et al.*, "Nonlinear optical phenomena in silicon waveguides: Modeling and applications," Opt. Express 15, 16604-16644 (2007)
5. J. Fargas-Cabanillas, D. Kramnik, A. Ramesh, *et al.*, "Tunable Source of Quantum-Correlated Photons with Integrated Pump...", FiO (2021).
6. D. Kramnik, *et al.* "Monolithically Integrated Feedback Control of Photon-Pair Generation by a Nonlinear...", CLEO, submitted (2022).
7. Xiaoying Liet *et al.*, "Measurement of co- and cross-polarized Raman" Opt. Express 13, 3579-3580 (2005).
8. I.Wang, J.M. Fargas Cabanillas, D. Kramnik, A. Ramesh, *et al.*, "Toward quantum electronic-photonics ...", CLEO, submitted (2022).